



Electric rotary multi-revolution
actuators

MODACT MONED, MOPED

Type numbers 52 030 - 52 036

MODACT MONEDJ

Type numbers 52 030 - 52 032

CERTIFICATE

Management system as per
EN ISO 9001 : 2008

In accordance with TÜV NORD CERT procedures, it is hereby certified that

ZPA Pečky, a.s.
Třída 5. května 166
289 11 Pečky
Czech Republic



applies a management system in line with the above standard for the following scope

**Development and production of electric actuators,
switch boards and sheet metal working.**

Certificate Registration No. 04 100 950161
Audit Report No. 624 362/300

Valid until 2012-09-24
Initial certification 1995-03-01

Certification Body
at TÜV NORD CERT GmbH

Praha, 2009-09-25

This certification was conducted in accordance with the TÜV NORD CERT auditing and certification procedures and is subject to regular surveillance audits.

TÜV NORD CERT GmbH

Langemarckstrasse 20

45141 Essen

www.tuev-nord-cert.com



TGA-ZM-07-06-00

BA51-10



www.zpa-pecky.cz

APPLICATION

The electric actuators **MODACT MONED, MOPED, MONEDJ** are designed for shifting valves and/or other elements for which they are suitable with their reversible rotary motion. Other using than that for controlling valves should be discussed with the manufacturer. The actuators can operate in circuits of remote control. The actuators can also operate in circuits of automatic regulation with the regime S4 - d25 %; 1200 h⁻¹.

OPERATING CONDITIONS, OPERATING POSITION

Operating conditions

The actuators **MODACT MONED, MOPED, MONEDJ** are resistant against influence of operating conditions and external effects of the classes AA7, AB7, AC1, AD5, AD7, AE5, AE6, AF2, AG2, AH2, AK2, AL2, AM2, AN2, AP3, BA4 and BC3 according to ČSN 33 2000-3.

When the actuator is installed on a free area it is recommended to fit it with a light shelter against direct impact of atmospheric effects. The shelter should overlap the actuator contour by at least 10 cm at the height of 20 – 30 cm.

When the actuators are to be installed in a working environment with temperature below -10 °C and in an environment with relative humidity above 80 %, it is always necessary to use an anti-condensation heater fitted to all actuators.

The electric actuators can be installed in areas with non-flammable and non-conductive dust, provided that this does not adversely influence their function. Here, it is necessary to strictly observe ČSN 34 3205. It is recommended to remove dust as soon as its layer is about 1 mm thick.

Notes:

The area under a shelter means the one where falling of atmospheric precipitations under and angle up to 60° from the vertical is prevented.

The electric actuator must be installed in a place where cooling air has a free access. Minimum distance from a wall for access of air is 40 mm. Therefore, the area where the electric actuator is installed must be sufficiently large, clean and ventilated.

Classes of external effects

Basic characteristics – excerpt from ČSN 33 2000-3:

- 1) AA7 – Combined action of surrounding temperature with relative humidity higher than 10 %.

Surrounding temperatures

Temperature [°C]	Type of actuator						Code
	MONED		MOPED		MONEDJ		
	DMS2 ED	DMS2	DMS2 ED	DMS2	DMS2 ED	DMS2	
-25 +60	✓	✓	✓	✓	✓	✓	–
-40 +60	✓	✓	✓	✓	✓	✓	F1
-50 +60	✓	✓	✓	✓	✓	✓	F
-60 +60	✓	✗	✗	✗	✗	✗	FF
-25 +80	✓*	✗	✓*	✗	✗	✗	T
-40 +80	✓*	✗	✓*	✗	✗	✗	F1T
-50 +80	✓*	✗	✓*	✗	✗	✗	FT

Note: ✓ – available version
 ✗ – not available
 ✓* – except for the version with current transducer of position, with analog control module, and/or with built-in display

- 2) AB7 – Surrounding temperature identical with point 1. The lowest relative humidity 10 %; the highest relative humidity 100 % with condensation.
- 3) AC1 – Altitude ≤ 2 000 m a.s.l.
- 4) AD5 – Spouting water; water can spout in any direction.
 AD7 – Shallow dipping; possibility of occasional partial or complete covering (*for the type MOPED only*)
- 5) AE5 – Moderate dustiness; medium dust layers; fall-out of dust more than 35 and max. 350 mg/m² per day.
 AE6 – Heavy dustiness; thick layers of dust; fall-out of dust more than 350 and max. 1000 mg/m² per day.
 (*for the type MOPED only*)

- 6) AF2 – Occurrence of corrosive or polluting substances is atmospheric. Presence of corrosive polluting substances is significant.
- 7) AG2 – Medium mechanical stress. In common industrial processes.
- 8) AH2 – Medium vibrations. In common industrial processes.
- 9) AK2 – Serious danger of growth of plants or moulds.
- 10) AL2 – Serious danger of occurrence of animals (*insects, birds, small animals*).
- 11) AM2 – Harmful effects of released stray currents
- 12) AN2 – Medium solar radiation. Intensity > 500 and 700 W/m².
- 13) AP3 – Medium seismic effects. Acceleration > 300 Gal 600 Gal
- 14) BA4 – Personal qualification. Instructed staff.
- 15) BC3 – Frequent contact of persons with earth potential. Persons are in frequent contact with foreign conductive parts or stand on and conductive support.

Operating position

Working position of actuators **MODACT® MONED, MOPED, MONEDJ** actuators with plastic lubricant – any position; actuators with oil charge – position limited only by slope of electric motor axis – max. 15° under the horizontal level. In this way, reducing of service life of rubber sealing of the electric motor shaft by possible fragments or impurities from the oil filling is prevented.

When the actuator is assembled with the electric motor above the horizontal plane the oil filling should be topped up so that reliable lubrication of the motor pinion is ensured.

Lubrication

The actuators are lubricated with plastic consistent lubricants or gearbox oil PP 80.

Lubricants

Type number of actuator	Adjusting speed of output shaft [min ⁻¹]	Surrounding temperature [°C]						
		-25 +60	-40 +60	-50 +60	-60 +60	-25 +80	-40 +80	-50 +80
52 030, 52 031, 52 032 52 033, 52 034	up to 40	M	M	M	M	M	M	M
	above 40	O	O	–	–	O	O	–
52 035	up to 70	M	M	M	M	M	M	M
	above 70	O	O	–	–	O	O	–
52 036	up to 30	M	M	M	M	M	M	M
	above 30	O	O	–	–	O	O	–

Note: M – plastic lubricant
O – gearbox oil

OPERATION MODE, SERVICE LIFE OF ACTUATORS

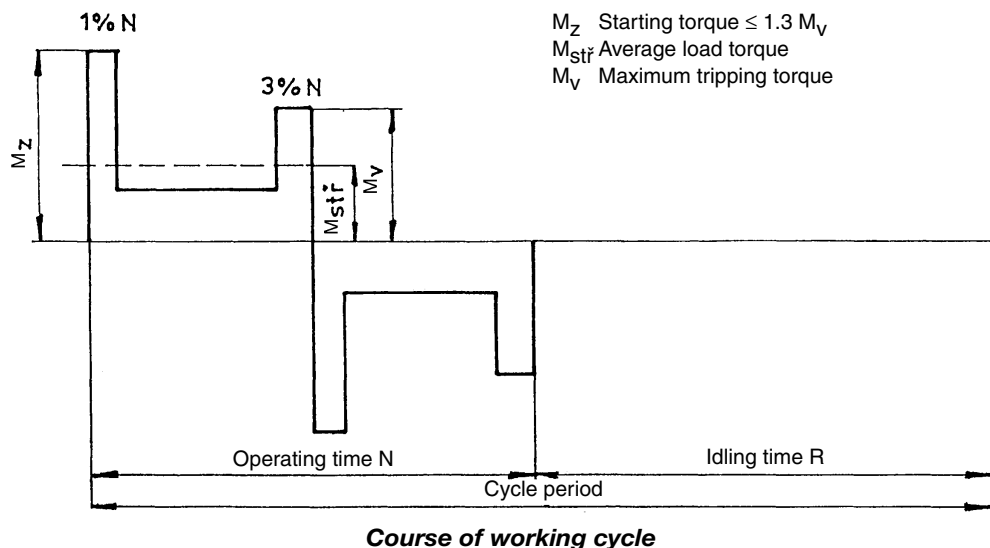

Operation mode

The actuators can be operated with the type of loading S2 according to ČSN EN 60 034-1. The run period at temperature +50 °C is 10 minutes; the mean value of loading torque should not exceed 60 % of the value of maximum tripping torque M_V . The actuators can also work in the regime S4 (*interrupted run with start-up*) according to ČSN EN 60 034-1. Load factor $N/N+R$ is max. 25 %; the longest working cycle $N+R$ is 10 minutes (*course of working cycle is shown in the figure*). The highest number of closing operations in automatic regulation is 1200 cycles per hour. Mean value of loading torque with load factor 25 % and surrounding temperature +50 °C is not higher than 40 % of maximum tripping torque M_V .

The highest mean value of loading torque is equal to rated torque of the actuator.

Service life of actuators

Service life of the electric actuators is at least 6 years.

The actuator designed for shut-off valves must be able to perform at least 10,000 working cycles (*Close-Open-Close*).

The actuator designed for regulation purposes must be able to perform at least 1 million cycles with running time (*when the output shaft is moving*) at least 250 hours. Service life in operating hours (*h*) depends on loading and number of switching actions. High frequency of switching is not always beneficial for precision of regulation. For reaching the longest possible faultless period and service life, it is recommended to set frequency of switching to the lowest possible number of switching actions necessary for the given process. Orientational data of service life derived from the set regulation parameters are shown in the following table.

Service life of electric actuators for 1 million starts

Service life [h]	830	1 000	2 000	4 000
Number of starts [1/h]	Max. number of starts 1200	1 000	500	250

TECHNICAL DATA

Supply voltage

Supply voltage of electric motor: **MODACT MONED, MOPED** 3 x 230/400 V, +10 %, -15 %, 50 Hz ± 2 %
3 x 220/380 V +10 %, -15 %, 50 Hz; +3 % -5 %
MODACT MONEDJ 1 x 230 V, +10 %, -15 %, 50 Hz ± 2 %
1 x 220 V +10 %, -15 %, 50 Hz; +3 % -5 %
(*or according to data on the rating plate*)

Actuators designed to operate at another voltage and frequency than those given above are available upon special request. For more details, refer to the Technical conditions.

Protective enclosure

Protective enclosure of actuators: **MODACT MONED, MONEDJ** – IP 55 according to ČSN EN 60 529
MODACT MOPED – IP 67 according to ČSN EN 60 529

Noise

Level of acoustic pressure A max. 85 dB (A)
Level of acoustic output A max. 95 dB (A)

Tripping torque

Tripping torque is set at the manufacturer according to the customer's requirements within the range given in Table No. 1 or No. 2. If setting of tripping torque is not required maximum tripping torque of the required type number of the electric actuator is set.

Starting torque

The starting torque of the actuator is a calculated value determined by the starting torque of the electric motor and the total gear ratio and efficiency of the actuator. After run reversion, the actuator can produce a starting torque for the duration of 1 to 2 revolutions of the output shaft when torque-limit switching is locked. This can take place in either end position or in any intermediate position.

Self-locking

The actuator is self-locking provided that the load only acts in the direction against motion of the actuator output shaft. Self-locking is ensured by a roller arrest immobilizing the electric motor rotor even in the case of manual control.

In order to observe safety regulations, the actuators cannot be used for driving transportation lifting devices with possible transport of persons or for installations where persons can stand under the lifted load.

Sense of rotation

When looking at the output shaft in the direction towards the control box, the CLOSE direction of rotation is identical with the clockwise sense.

Working stroke

The ranges of working stroke are given in Table No. 1 or No. 2.

Rising spindle

In the design variants with connecting dimensions, Shapes A and C, the actuators can be adapted for mounting to the valve with a rising spindle that projects over the upper end of the actuator output shaft in the end position of the valve. The space reserved for the rising spindle is clearly shown in the dimensional sketches. The user should mount a cylindrical guard of the rising spindle instead of the port cover at the control box top, if required. This guard has not been included in the delivery of the actuator.

Manual control

Manual control is performed directly by a handwheel (*without clutch*). It can be used even when the electric motor is running (*the resulting motion of the output shaft is determined by the function of the differential gear*). When the handwheel is rotated clockwise the output shaft of the actuator also rotates clockwise (*when looking at the shaft towards the control box*). On condition that the valve nut is provided with left-hand thread, the actuator closes the valve.

ACTUATOR OUTFIT

Position indicator

The actuator can be fitted with a local position indicator.

Anti-condensation heater

The actuators are fitted with an anti-condensation heater preventing condensation of water vapour. It is connected to the AC mains of voltage 230 V.

Local control

Local control serves for controlling the actuator from the site of its installation. It includes two change-over switches: one with positions „Remote control - Off - Local control”, the other „Open - Stop - Close“.

The former change-over switch can be built-in as two-pole or four-pole. The change-over switches are installed in a terminal-board box and the control elements on the lid of this terminal-board box.

Dynamic brake

The brake is an optional accessory to the actuators fitted with electronics DMS2 and DMS2 ED Control. After opening the switching element (*contactor or SSR*), it induces dynamic braking moment in the motor for several tenths of second. When the actuator is in a standstill no braking moment is exerted. The brake reduces dramatically time of the actuator run-down and regulation is thus more precise. The used brakes BR2 are controlled, impulse for action comes from the control unit. Corresponding variant of the brake is chosen according to the electric motor output and the type of switching elements.

Corresponding variant is chosen according to the electric motor power:

BR2 550 output up to 550 W
BR 2,2 output up to 2.2 kW

If higher outputs are to be braked electric motors of special version with an electromagnetic brake should be used.

Switching of electric motor, contactor unit

The actuators in variants Control are fitted with built-in reversing contactor combinations. These are assembled of two contactors and an over-current relay. The combination also includes mechanical blocking that prevents both contactors from being closed at the same time. This could, for instance, happen in case of wrong connection of jumpers on the terminal board. The blocking is not dimensioned for long-term action. The over-current relays protect the electric motor against over-loading and is dimensioned with respect to its output. According to the actuator version, the contactors are controlled by the regulator, change-over switch of local control or external input. Control voltage is

230 V / 50 Hz as a standard; it is supplied via contacts of position and/or moment micro-switches. Thus, these micro-switches need not be led out of the actuator.

The contactors used have a long mechanical service life and great reserve in switching ability; consequently, the electric service life is also sufficient for particular use. The thermal relay is chosen so that it would reliably protect the electric motor against overload. Set-up and outfit of the actuators provide for simple connection to power-supply and control circuits.

The power-supply circuits can be common for the whole group of actuators, which will save the cabling.

ELECTRIC PARAMETERS

External electric connection

a) Actuator terminal board

The electric actuator is equipped with a terminal board for connection to external circuits. This terminal board uses screw terminals allowing conductors with a maximum cross-section 4 mm² to be connected. Access to the terminal board is obtained after removal of the terminal box cover. All control circuits of the electric actuator are brought out to the terminal board. The terminal box is fitted with cable bushings for connecting the electric actuator. The electric motor is fitted with an independent box with a terminal board and a bushing.

b) Connector

According to the customer's requirements the **MODACT MONED, MOPED, MONEDJ** actuators can be fitted with the connector to provide for connection of control circuits. This connector uses screw terminals allowing conductors with a maximum cross-section 4 mm² to be connected. ZPA Pečky, a.s. also supplies a counterpart for the cable. In order to connect the cable to this counterpart it is necessary to use special crimping pliers.

Actuator internal wiring

The internal wiring diagrams of the **MODACT MONED, MOPED, MONEDJ** actuators with terminal designation are shown in the Appendix.

Each actuator is provided with its internal wiring diagram on the inner side of the terminal box. The terminals are marked on a self-adhesive label attached to a carrying strip under the terminal block.

Isolation resistance

Isolation resistance of electric control circuits against the frame and against each other is min. 20 Mohm. After a dump test, isolation resistance of control circuits is min. 2 Mohm. Isolation resistance of the electric motor is min. 1.9 Mohm. See Technical specifications for more details.

Electric strength of electric circuits isolation

Circuits of anti-condensation heater		1 500 V, 50 Hz
Electric motor	Un = 1 x 230 V	1 500 V, 50 Hz
	Un = 3 x 230/400 V	1 800 V, 50 Hz

Deviations of basic parameters

Tripping torque	±12 % of max. value of range
Adjusting speed	- 10 % of max. value of range +15 % of rated value (<i>idle run</i>)

Protection

The actuators are fitted with one internal and one external protection terminal for ensuring protection against electric shock injury according to ČSN 33 2000-4-41. One protection terminal is also installed on the electric motor. The protection terminals are marked according to ČSN EN 60 417-1 and 2 (013760).

DESCRIPTION OF ACTUATOR

The electric actuators are designed for direct mounting on the controlled element. They are connected by a flange and a clutch according to ČSN 18 6314. The actuator flanges also comply with ISO 5210. The clutches for transmitting motion to the valve are:

- shape A (with adapter), according to ISO 5210 and DIN 3210
- shape B1 (with adapter), according to ISO 5210 (shape B according to DIN 3210)
- shape B3 (without adapter), according to ISO 5210 (shape E according to DIN 3210)
- shape D (without adapter), according to DIN 3210
- shape C (without adapter), according to DIN 3338

The adapters are fitted between the electric actuator and the valve.

The asynchronous electric motor drives, via a drive gearing, the central wheel of the differential gear located in the load-bearing box of the electric actuator (*force gear*). In motor control, the crown wheel of the epicyclic differential is held in constant position by a self-locking screw gear. The hand wheel connected with the screw provides for alternative manual control even when the electric motor is running, without any danger to the operator.

The output shaft is fix-connected with the epicyclic gear catch driver and passes on to the control box where all control elements of the actuator are installed.

The control elements are accessible after removing the control box lid.

The actuators designated **MONED**, **MONEDJ** are used with electric motors with the protective enclosure IP 55; the actuators designated **MOPED** with electric motors with the protective enclosure IP67. The complete actuator has a protective enclosure according to the electric motor used.

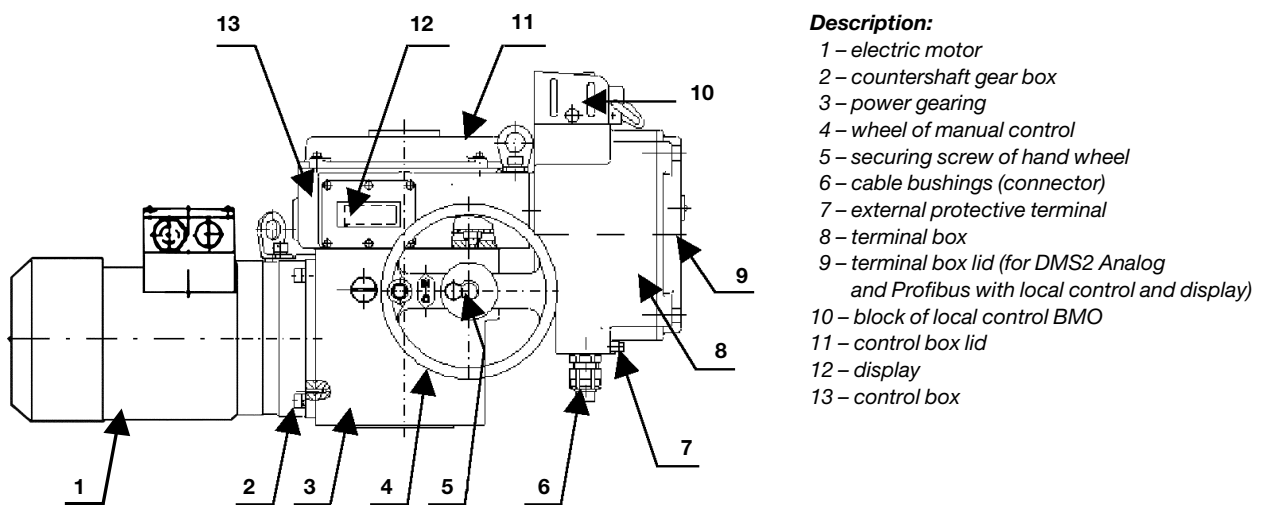

Fig. 1 – Actuator set-up (with electronic system DMS2 ED)

ELECTRONIC OUTFIT

Electro-mechanical control board is replaced with the electronic system **DMS2** or **DMS2 ED**. Both systems scan position of the output shaft and torque of the electric actuator by contact-free magnetic sensors. The sensor of the output shaft position is absolute and does not require any backup power supply in case supply voltage is disconnected during operation of the electric actuator. Both systems can be set and monitored by a computer with controlling programme or manually without a computer.

The more simple system **DMS2 ED** substitutes electromechanical parts and/or provides for controlling the electric actuator by input analog signal as in the version Control.

The system **DMS2** enables the electric actuator to be used for two-position and three-position regulation or to be connected to the industrial bus bar Profibus.

DMS2 ED

Basic outfit:

Control unit

It also contains the sensor of position of the output shaft, 4 push-buttons and 3 signal LEDs for setting and checking the actuator.

Torque-limit unit

Source unit

Contacts of seven relays (*MO, MZ, PO, PZ, SO, SZ, Ready*) are connected to the terminal board; state of each relay is signalized by LED. The unit enables the heating resistor to be connected and controlled by the thermostat.

Optional outfit:

Feedback signal 4 – 20 mA
 Analog regulator
 Position Indicator – LED display
 Local control
 Contactors or block of contact-less control – for version Control
 Electronic brake

Main merits:

Absolute scanning of position independent of backup power supply.
 Simple setting by 4 push-buttons, computer PC or PDA.
 Possibility of back-up making of set parameters on PC.
 Intended for direct substitution of electromechanical components of the electric actuator.

Parameters:

Scanning of position	Contact-less magnetic
Scanning of torque	Contact-less magnetic
Working stroke	2 – 1700 rev.
Blocking of torque	0 – 20 s at reversing in limit positions
Input signal	0 (4) – 20 mA with switched on regulator function
Output signal	Local/Remote control, Local open/close
	7 x relay 250 V AC, 3 A (<i>MO, MZ, PO, PZ, SO, SZ, READY</i>)
	Position signal 4 – 20 mA max. 500 ohm, active/passive, galvanic-isolated
	LED display (<i>optional</i>)
Power supply of electronic	Electronic brake (<i>optional</i>)
	230 V AC, 50 Hz, 4 W, over-voltage category II

DMS2**Basic outfit:**

Control unit	It also includes a sensor of the output shaft position, 2 signal LED.
Torque-limit unit	
Source unit	It includes: 2 relays for electric motor control; Relay Ready with change-over contact connected to the terminal board; Signalling relays 1 – 4 with one pole of the switching contact connected to the terminal board; Second poles of the switching contacts of relays 1 – 4 are interconnected and brought out to the terminal COM. Heating resistor switched by a thermostat is connected to the unit. The unit controls power switches of the electric motor (<i>contactors or contact-less switching</i>). The electronic brake can be connected to the unit.
Unit of display	Two-row display, 2 x 12 alpha-numeric characters.
Unit of push-buttons	Push-buttons " Open ", " Close ", " Stop ", selector switch " Local ", " Remote ", " Stop ".

Recommended outfit:

Electronic brake – the actuator can be fitted with the electronic brake – this reduces the actuator run-down after switching-off.

Optional outfit (*the electric actuator must be fitted with one of these units*):

Unit of two- and three-position control – Control of the electric actuator by shifting to position "Open" and "Close" or by analog signal 0 (4) – 20 mA.

Unit of connection Profibus – control of the electric actuator by industrial bus bar Profibus.

The electronic control DMS2 checks, within its function, sequence and fall-out of phases of supply voltage too.

Example of wiring diagram of electronics **DMS2 ED** in version
Substitution of electro-mechanical board
(actuators MODACT MONED, MOPED, MONEDJ)

E0001

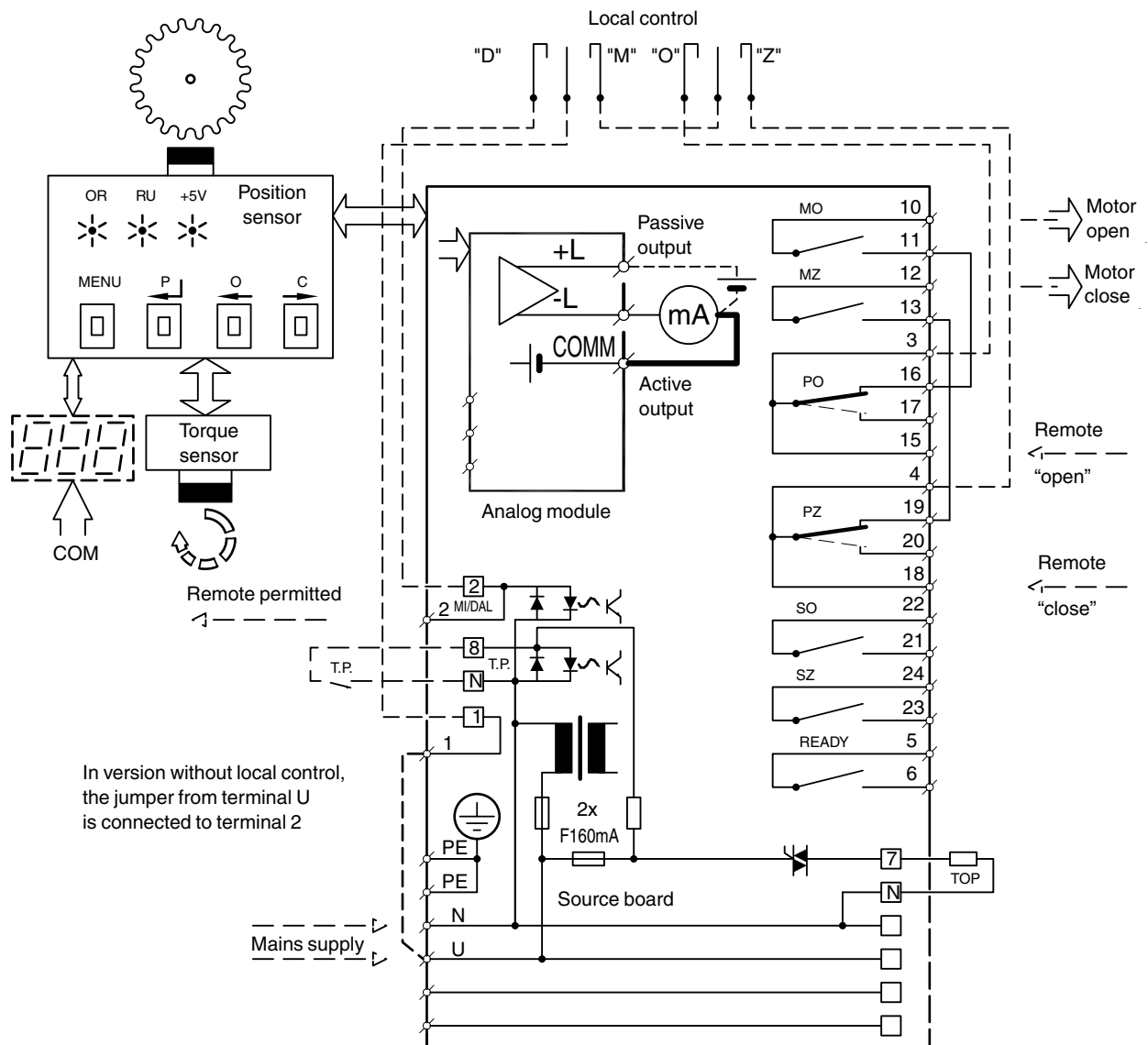

Note: Here, contacts of relays MO, MZ, SO, SZ are shown with power supply switched off; with power supply switched off contacts PO, PZ are shifted to the position drawn in dashed line.

Example of wiring diagram of electronics **DMS2 ED** in version **Substitution of electro-mechanical board with connector connection**
(actuators MODACT MONED, MOPED)

E0028

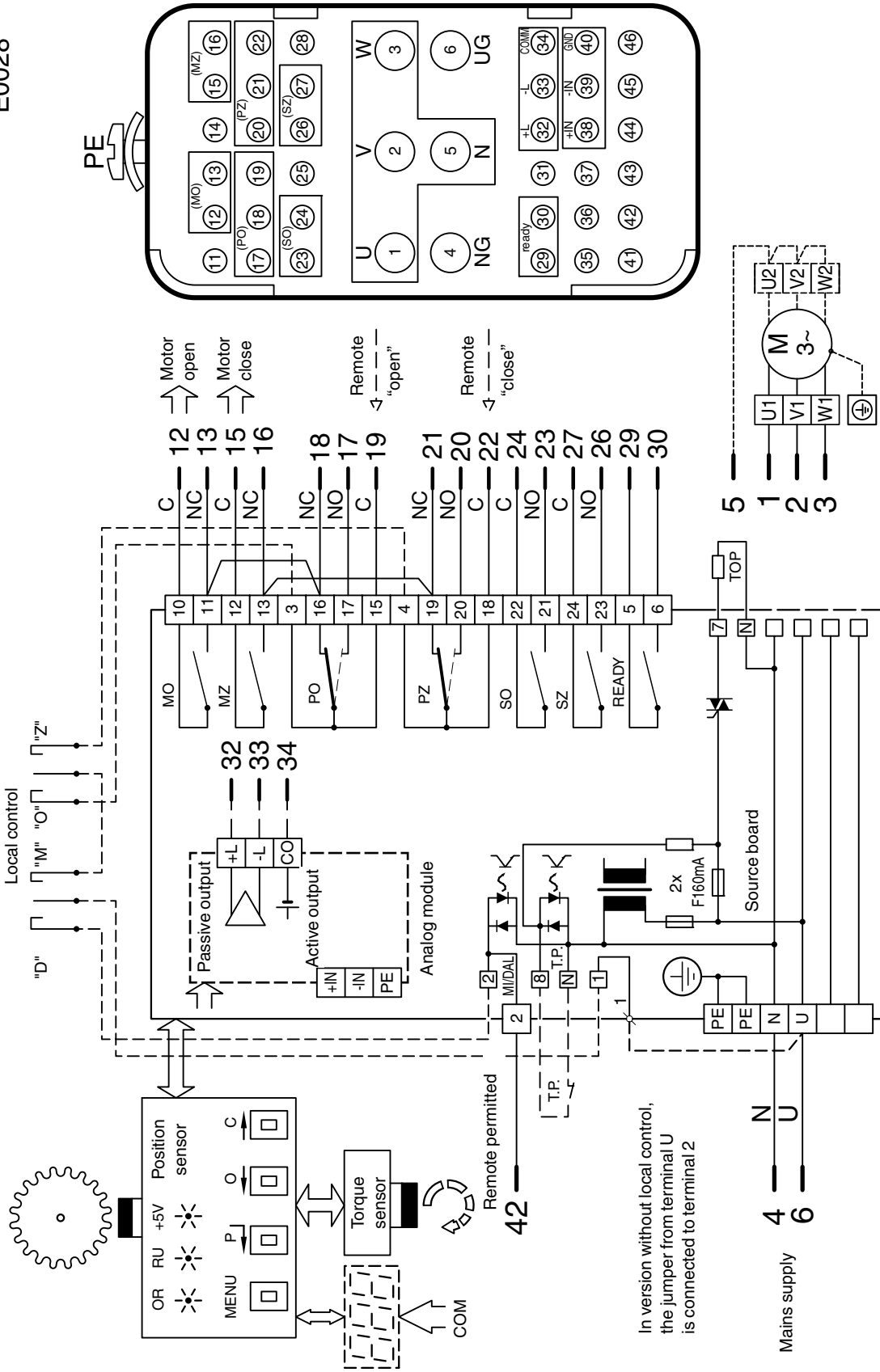

Example of wiring diagram **Substitution of electro-mechanical board with contactors and three-phase electric motor (actuators MODACT MONED, MOPED)**

E0002

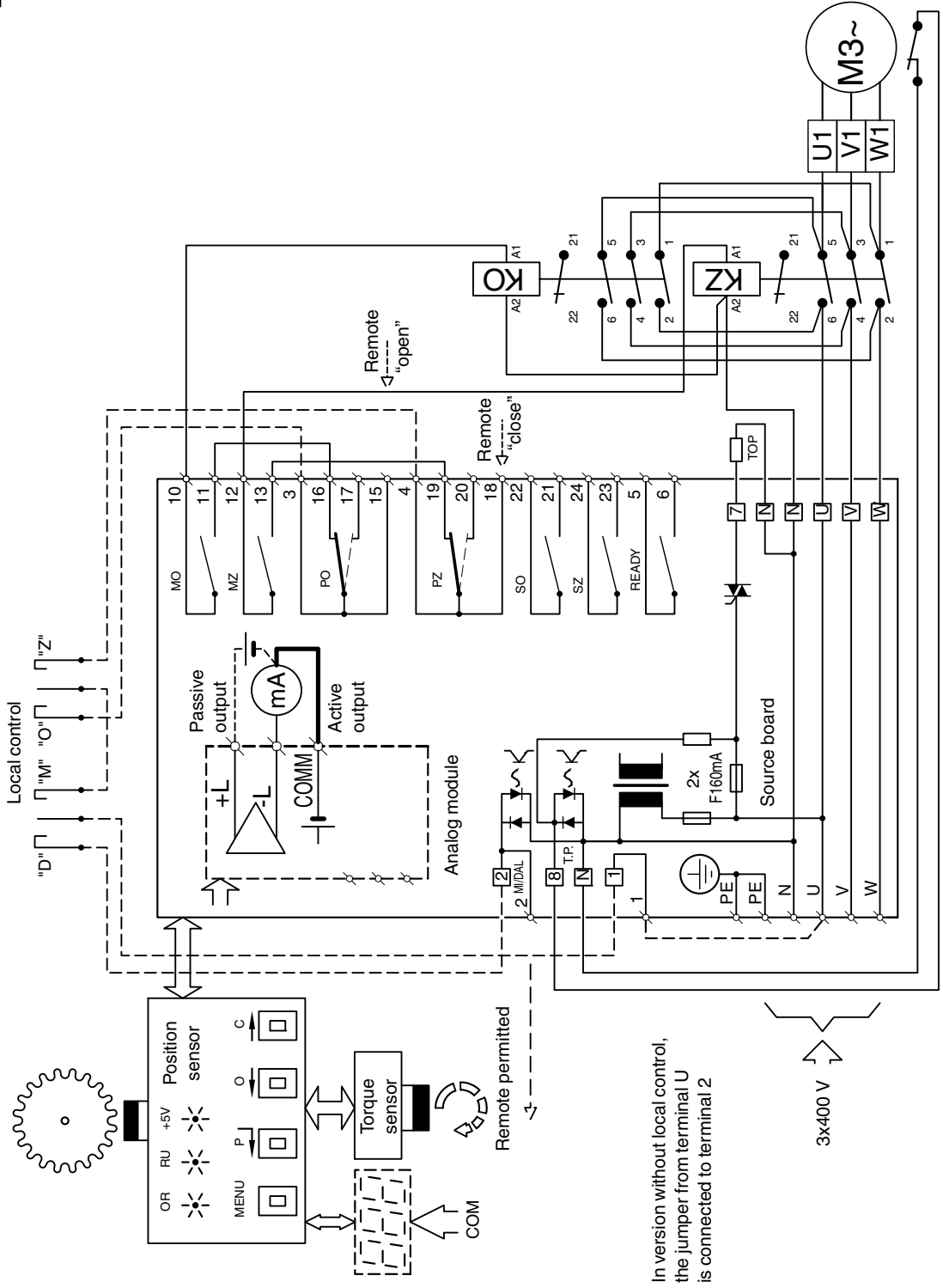

Example of wiring diagram of electronics DMS2 ED in version Control (actuators MODACT MONED, MOPED)

E0003

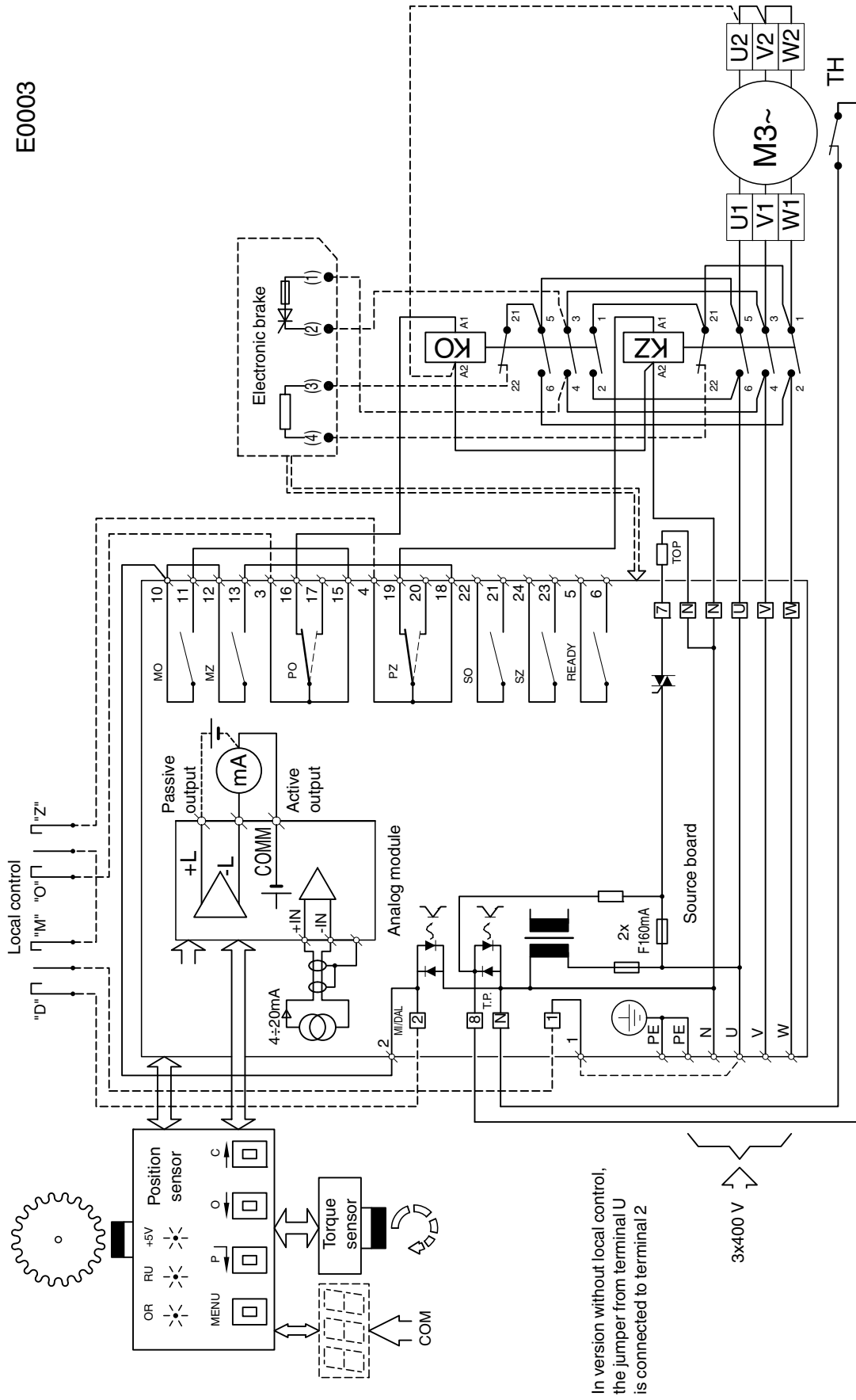

In version without local control, the jumper from terminal U is connected to terminal 2

Note: Here, contacts of relays MO, MZ, SO, SZ are shown with power supply switched off; with power supply switched on contacts PO, PZ are shifted to the position drawn in dashed line.

Example of wiring diagram of electronics **DMS2 ED** in version **Control with connector connection**
(actuators MODACT MONED, MOPED)

E0027

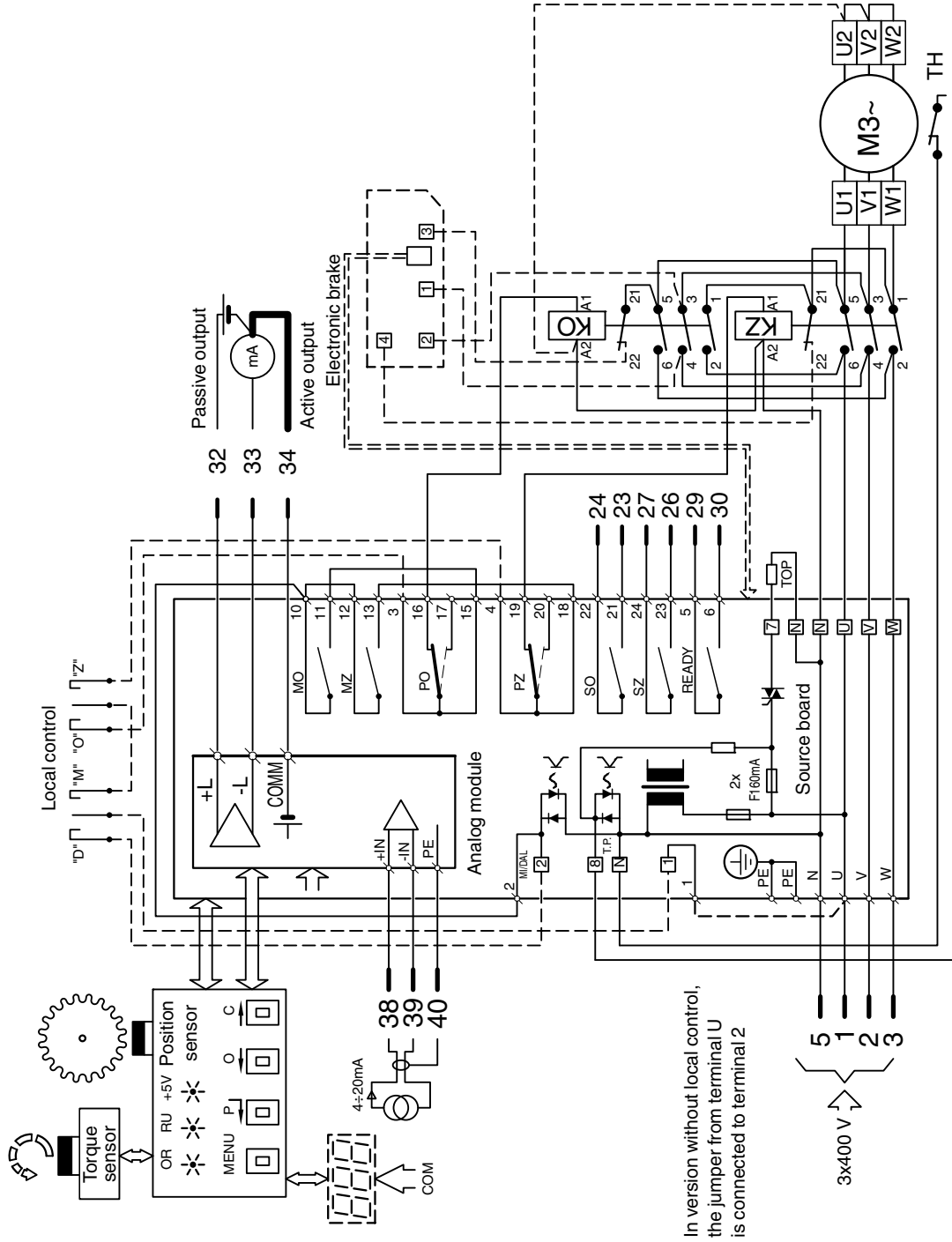

Example of wiring diagram of electronics DMS2 ED in version Control with contact-less switching of electric motor

E0004

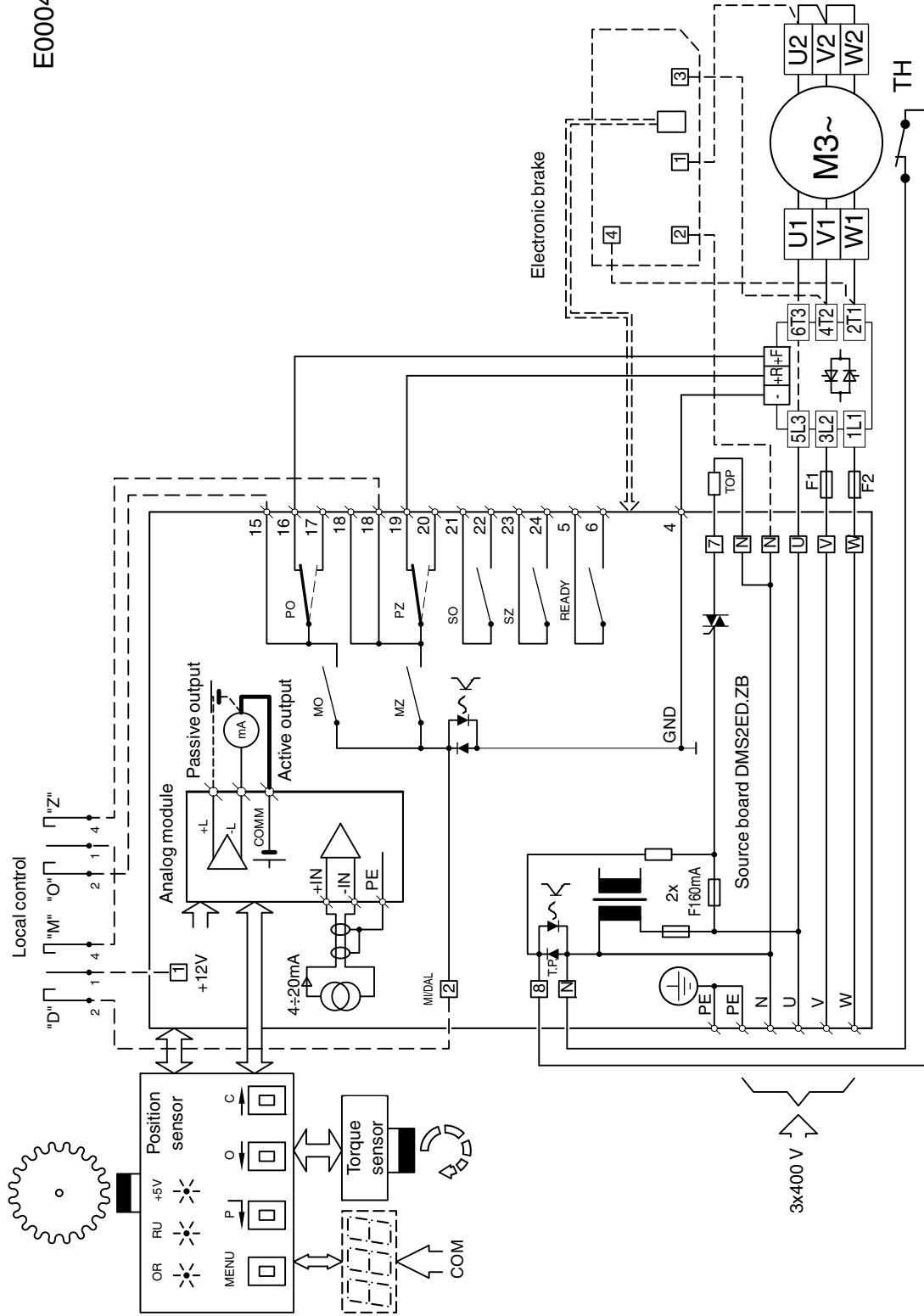

Note: Here, contacts of relays MO, MZ, SO, SZ are shown with power supply switched off; with power supply switched on, PO, PZ are shifted to the position drawn in dashed line.

Example of wiring diagram of electronics DMS2 ED in version Control (actuators MODACT MONEDJ)

E0005

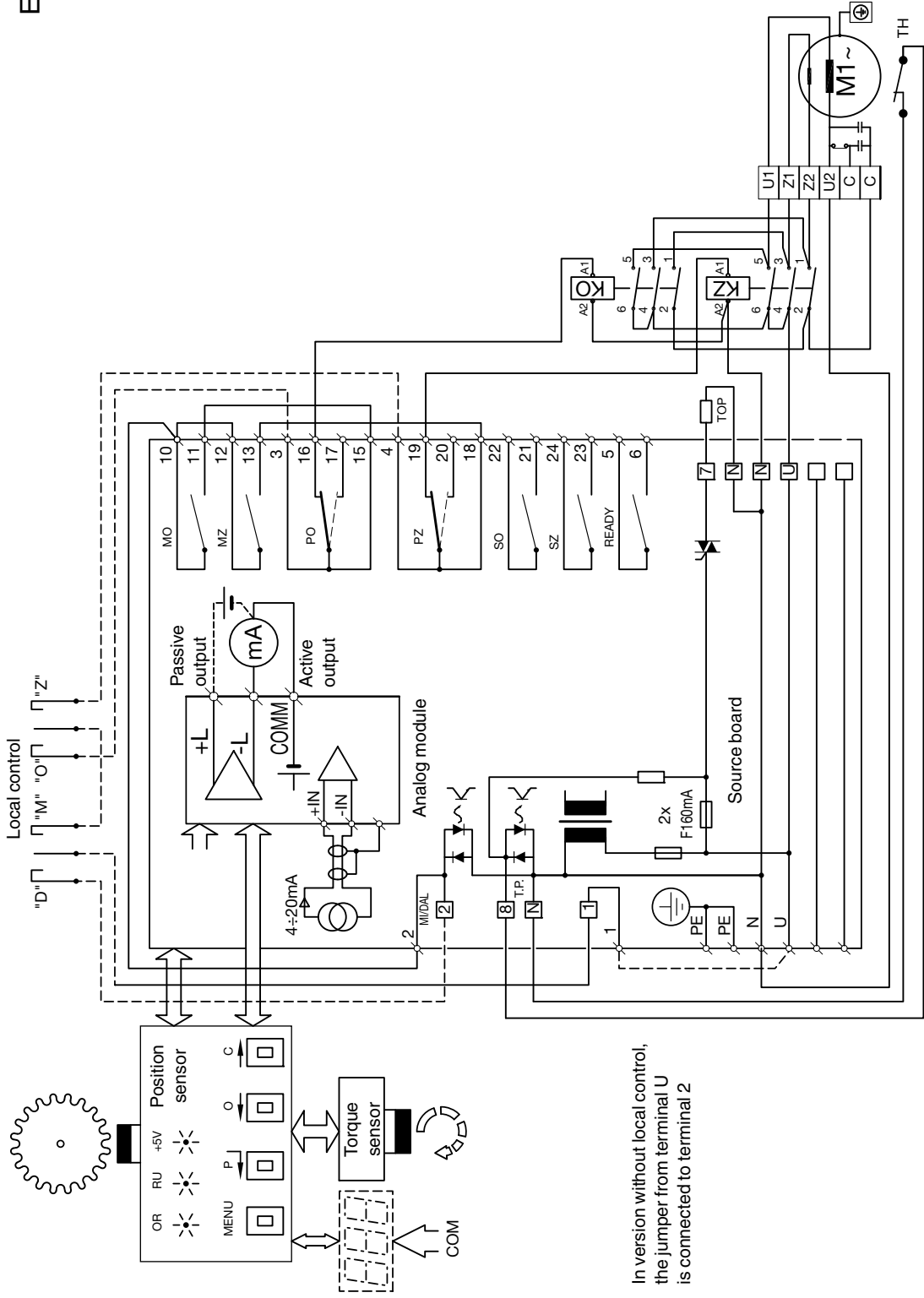

In version without local control, the jumper from terminal U is connected to terminal 2

Note: Here, contacts of relays MO, MZ, SO, SZ are shown with power supply switched off; with power supply switched off contacts PO, PZ are shifted to the position drawn in dashed line.

Example of wiring diagram of electronics **DMS2 ED** in version **Control** with contact-less switching of electric motor, with connector connection

E0026

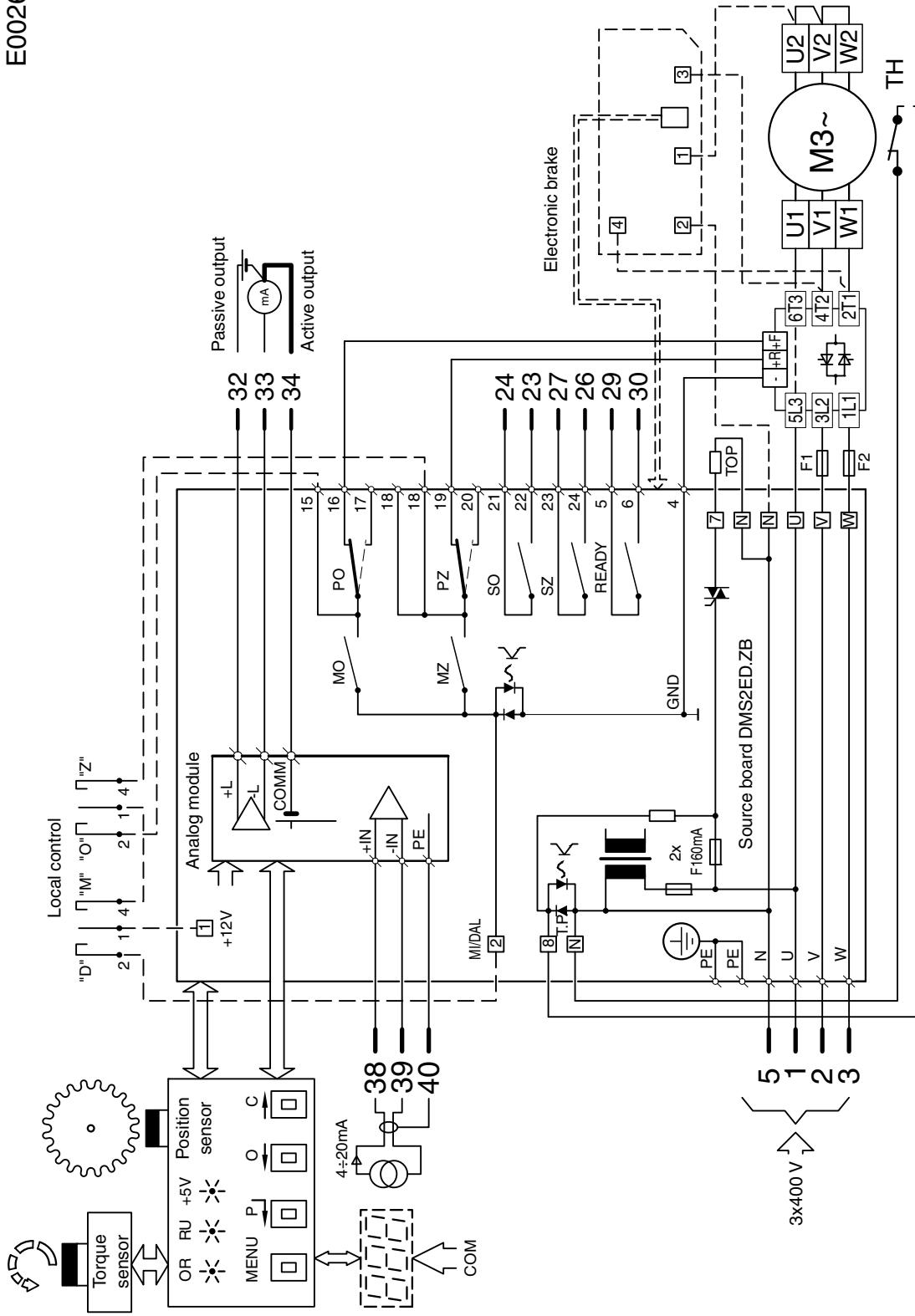

Example of wiring diagram of electronics **DMS2 Analog** in version **Control (actuators MODACT MONED, MOPED)**

E0006

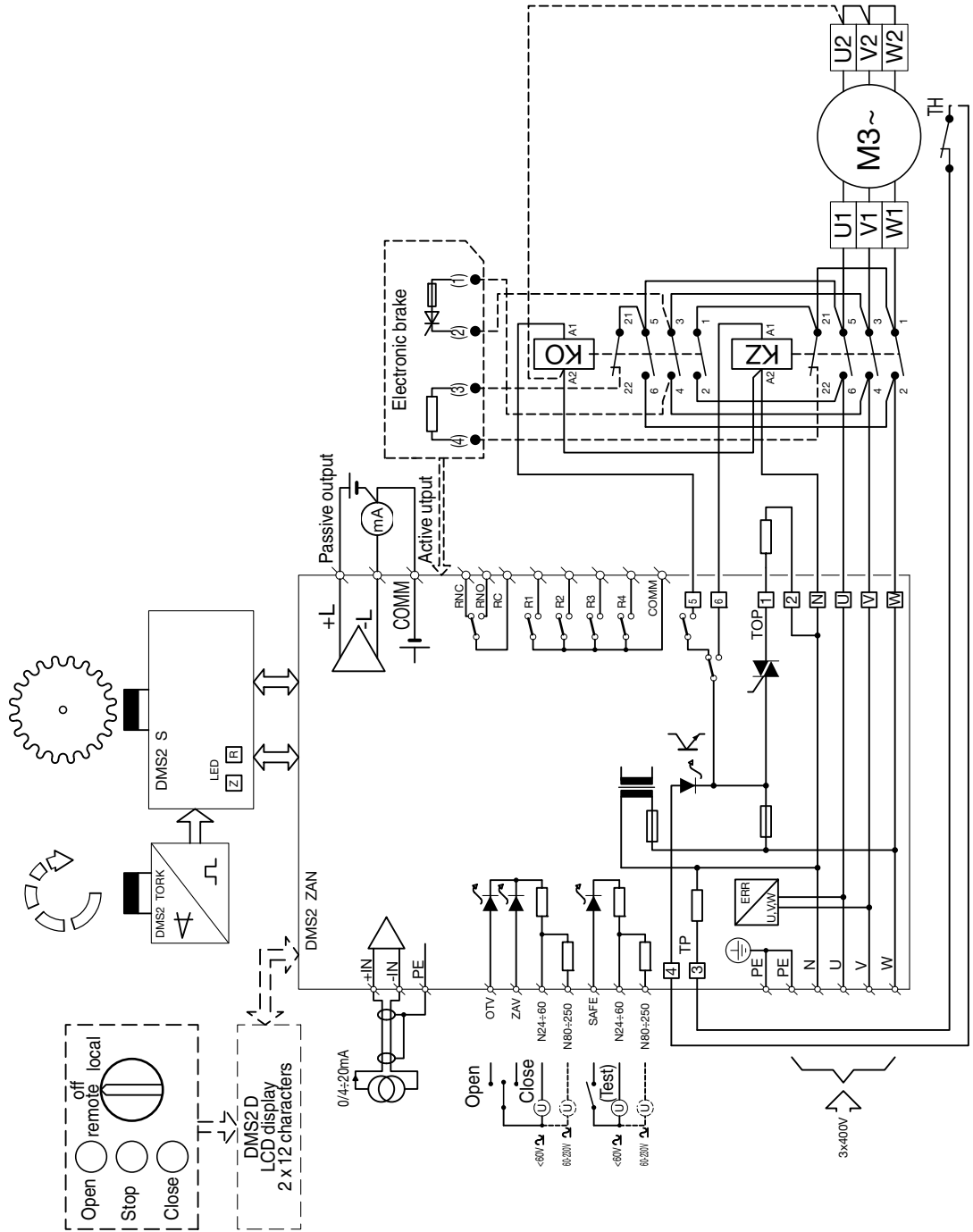

Example of wiring diagram of electronics **DMS2 Analog** in version **Control** with connector connection
(actuators MODACT MONED, MOPED)

E0032

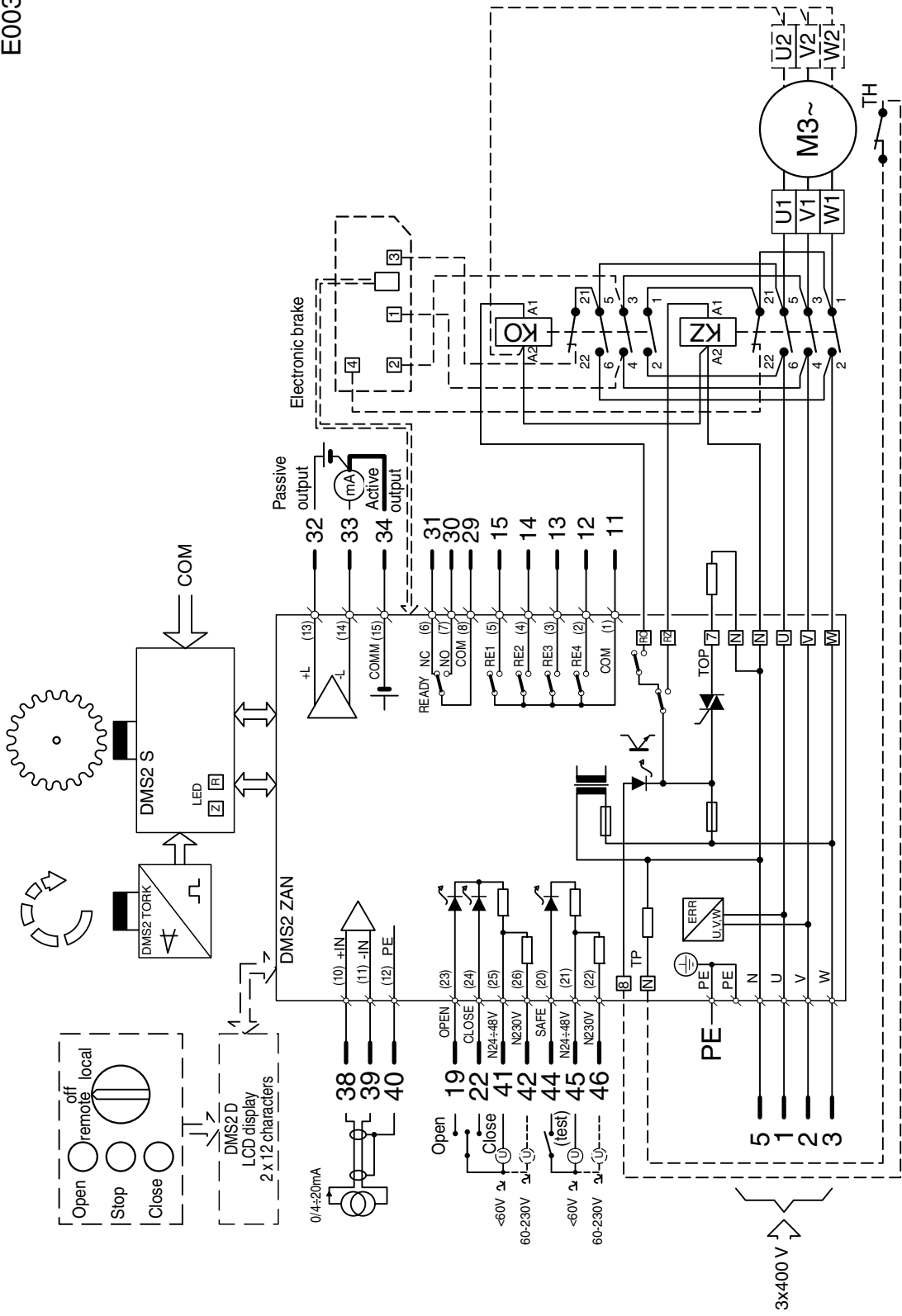

Example of wiring diagram of electronics **DMS2 Analog** with contact-less switching of electric motor
(actuators MODACT MONED, MOPED)

E0031

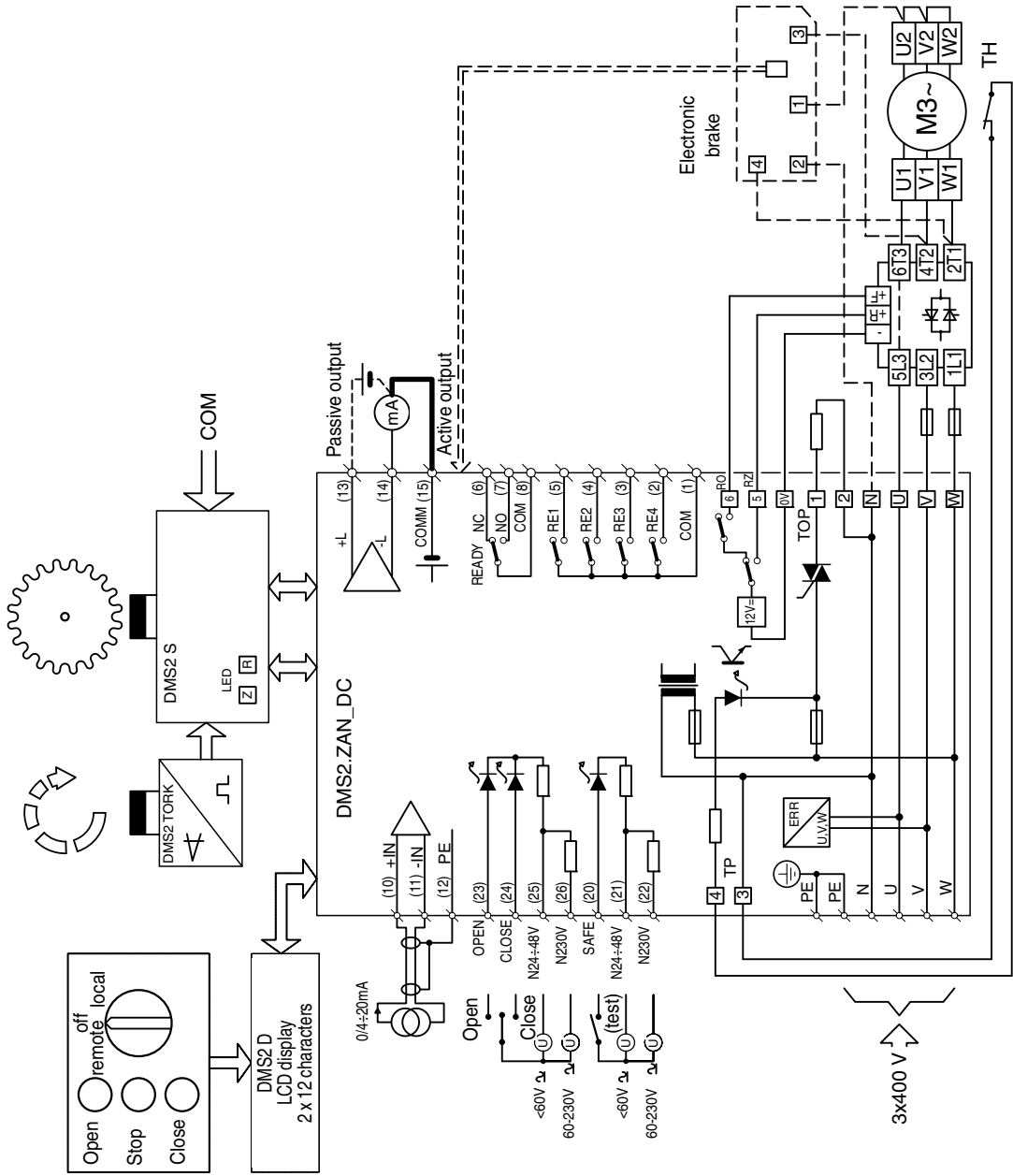

Example of wiring diagram of electronics DMS2 Analog (actuators MODACT MONEDJ)

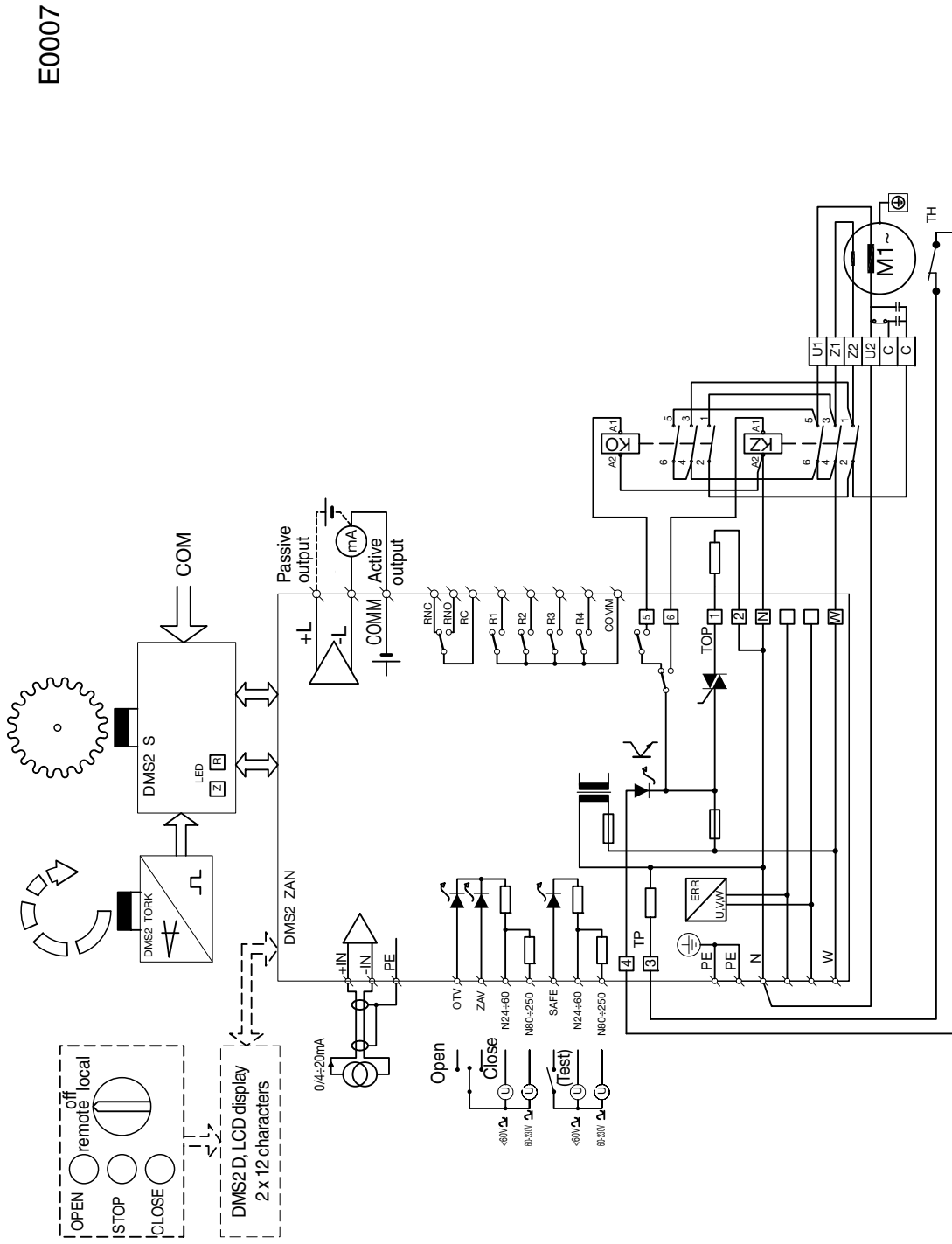

E0007

Example of wiring diagram of electronics **DMS2 Profibus (actuators MODACT MONED, MOPEd)**

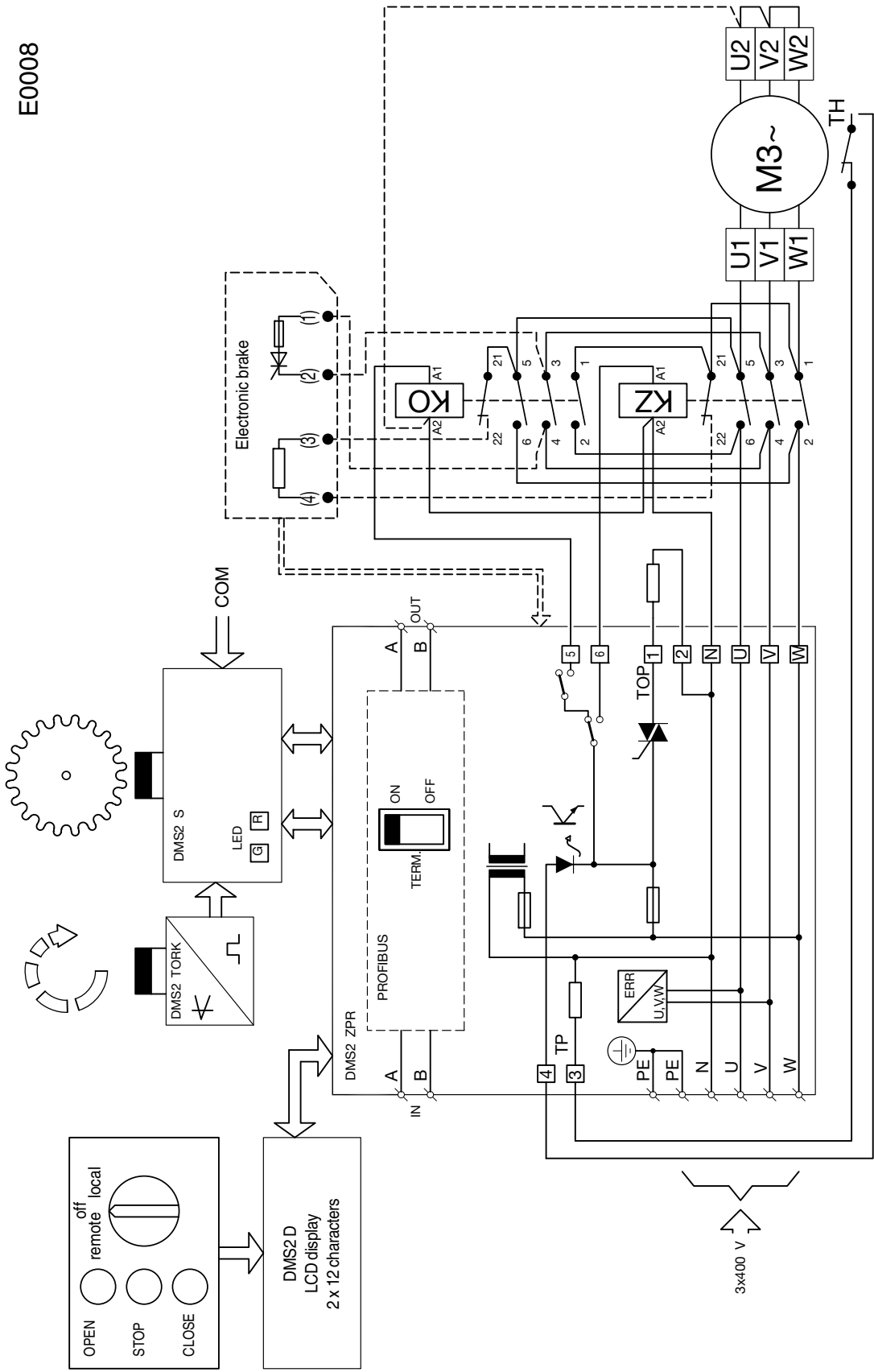

E0008

Example of wiring diagram of electronics **DMS2 Profibus** with contact-less switching of electric motor
(actuators MODACT MONED, MOPED)

E0033

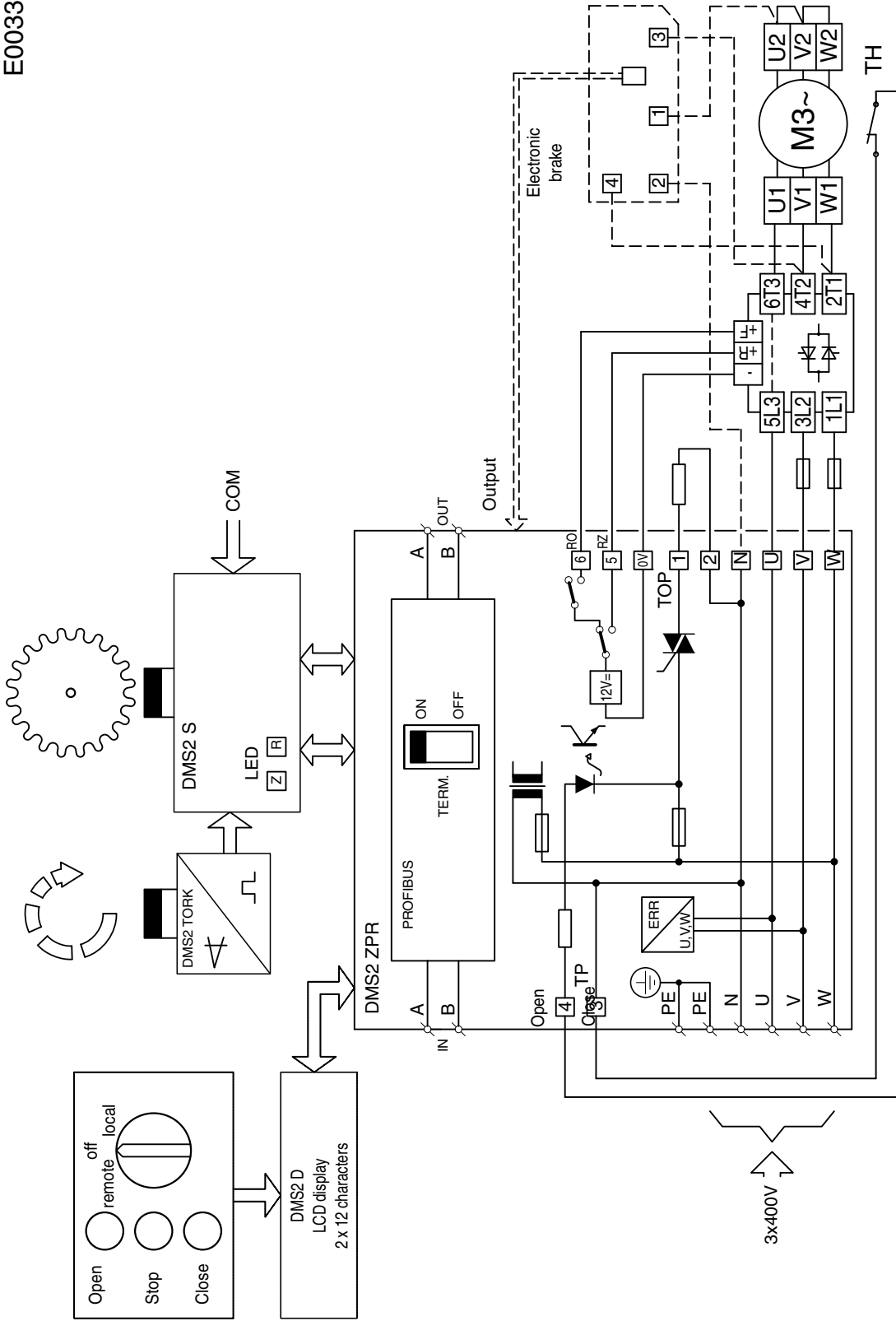

Example of wiring diagram of electronics **DMS2 Profibus** in version **Control (actuators MODACT MONEDJ)**

E0009

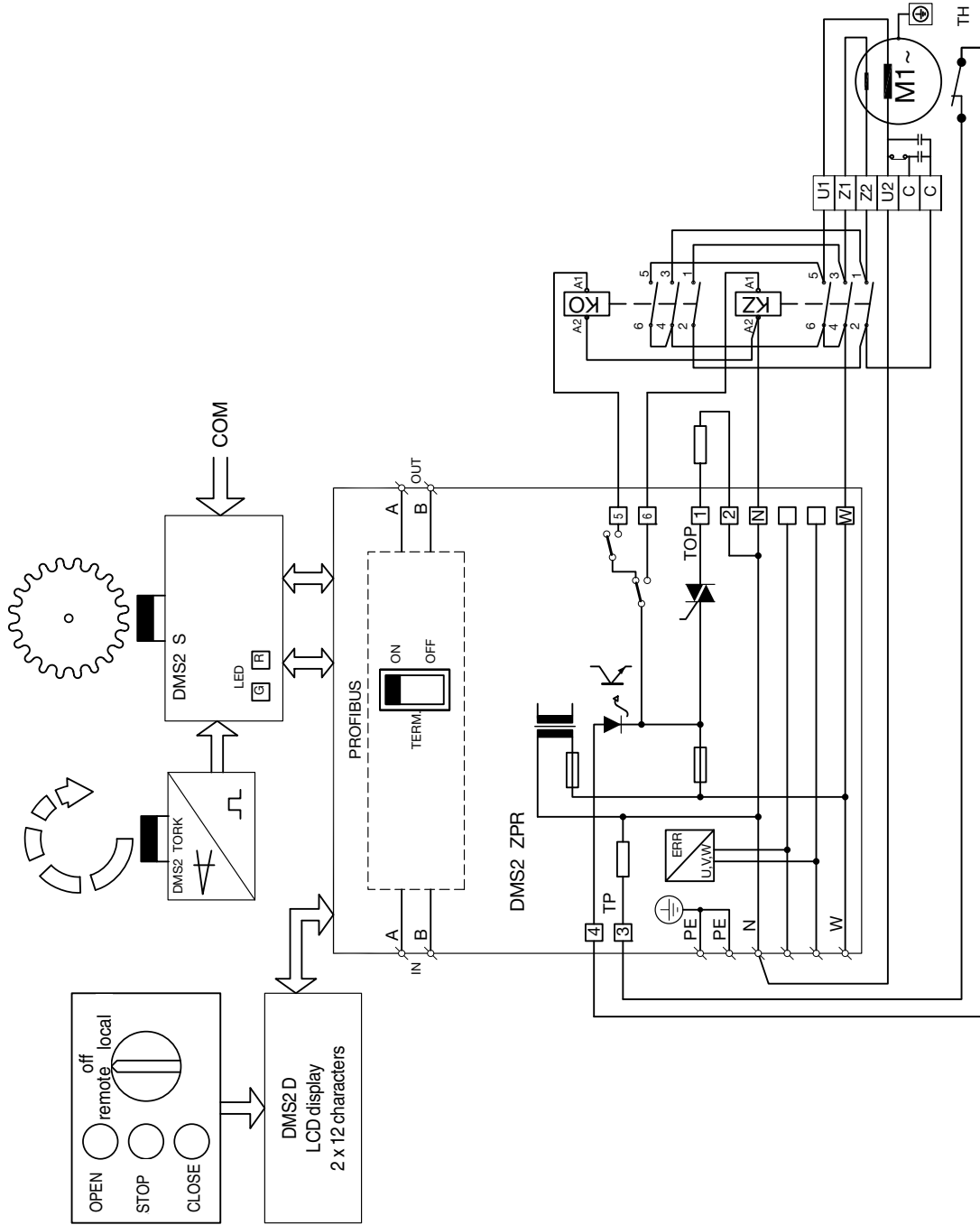

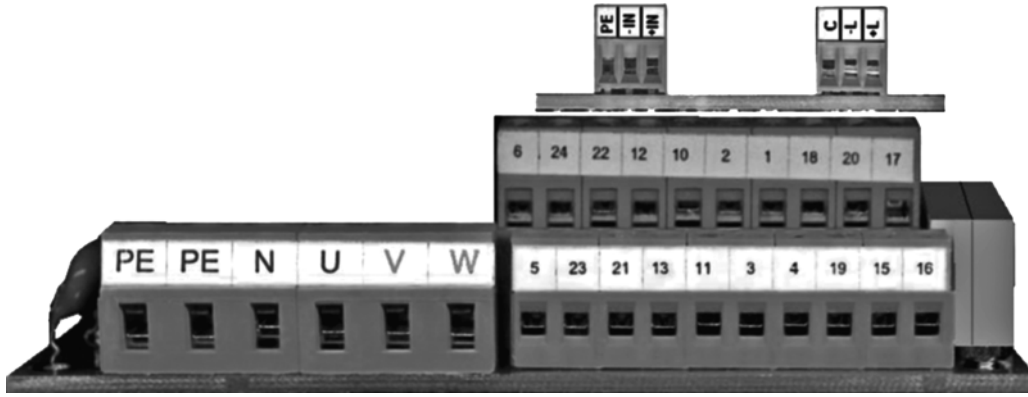

The terminal board of the actuator with electronics DMS2 ED.

Note: If the actuator is of one-phase version the supply mains inlet is only connected to the terminals **PE, N U**. The terminals **V, W** will remain unconnected.

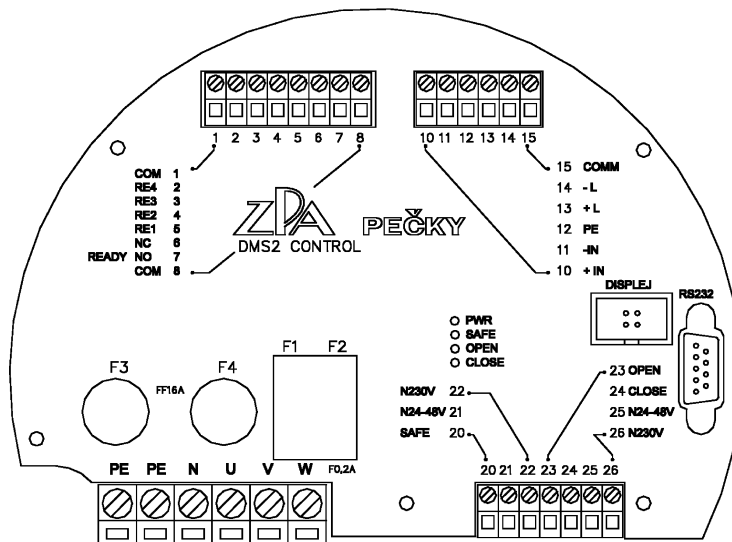

Terminal board of DMS2 Analog

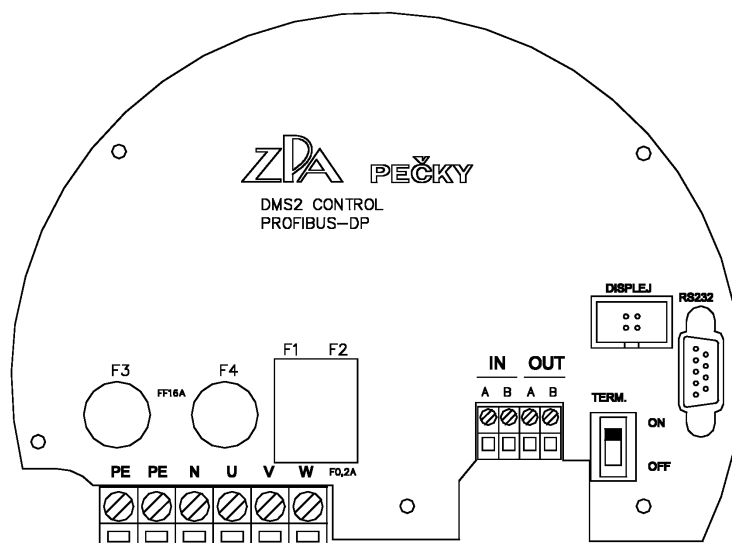

Terminal board of DMS2 Profibus

Note: The actuators **MONEDJ** are supplied from single-phase mains. The inlet is connected to the terminal **N** (middle conductor) and **W** (phase conductor). The terminals **U, V** will remain unconnected.

Table 1 – MODACT MONED, MOPED electric actuators – basic parameters
 – supply voltage 3 x 230/400 V, 50 Hz, MODACT MONED), IP 67 (MODACT MOPED)

Type marking	Moment [Nm]		Adjusting speed [1/min]	Working stroke [revol.]	Type of lubricant	Electric motor				Weight [kg]		Type No.					
	Tripping	Starting				Type	Power [kW]	RPM [1/min]	I _n (400 V) [A]	I _Z	I _n	basic	additional				
MONED (MOPED) 40/135-7		135	7			1x7070-8AB	0.09	630	0.36	2.2	28	6	7	8	9	10	11
MONED (MOPED) 40/220-9		220	9			1x7070-6AA	0.18	850	0.74	2.3	28						
MONED (MOPED) 40/135-15		135	15			1x7070-6AA	0.18	850	0.74	2.3	28						
MONED (MOPED) 40/100-25	20 – 40	100	25			1x7070-4AB	0.25	1350	0.77	3.0	27						
MONED (MOPED) 40/60-40		60	40			1x7070-4AB	0.25	1350	0.77	3.0	27						
MONED (MOPED) 40/95-50		95	50		●	1x7070-2AA	0.37	2740	1.00	3.5	27						
MONED (MOPED) 40/60-80		60	80		●	1x7070-2AA	0.37	2740	1.00	3.5	27						
MONED (MOPED) 80/135-7		135	7			1x7070-8AB	0.09	630	0.36	2.2	28						
MONED (MOPED) 80/220-9		220	9			1x7070-6AA	0.18	850	0.74	2.3	28						
MONED (MOPED) 80/135-15	40 – 80	135	15			1x7070-6AA	0.18	850	0.74	2.3	28						
MONED (MOPED) 80/100-25		100	25			1x7070-6AA	0.18	850	0.74	2.3	28						
MONED (MOPED) 75/95-40	40 – 75	95	40	2 – 1880		1x7070-4AB	0.37	1370	1.05	3.3	28						
MONED (MOPED) 70/95-50	40 – 70	95	50		●	1x7070-2AA	0.37	2740	1.00	3.5	27						
MONED (MOPED) 70/90-80		90	80		●	1x7073-2AA	0.55	2800	1.36	4.3	28						
MONED (MOPED) 125/200-7		200	7			1x7073-8AB	0.12	645	0.51	2.2	28						
MONED (MOPED) 125/220-9	80 – 125	220	9			1x7070-6AA	0.18	850	0.74	2.3	28						
MONED (MOPED) 125/200-15		200	15			1x7073-6AA	0.25	860	0.79	2.7	28						
MONED (MOPED) 120/155-25	80 – 120	155	25			1x7073-4AB	0.37	1370	1.05	3.3	27						
MONED (MOPED) 115/150-50	80 – 115	150	50			1x7073-2AA	0.55	2800	1.36	4.3	28						
MONED (MOPED) 200/320-9	100 – 200	320	9		●	1x7073-6AA	0.25	850	0.78	2.7	28						
MONED (MOPED) 200/260-15	100 – 200	260	15			1x7073-4AB	0.37	1370	1.05	3.3	27						
MONED (MOPED) 200/310-25	100 – 200	310	25			1x9073-4LA	0.60	1340	1.65	3.6	28						
MONED (MOPED) 200/260-50	100 – 200	260	50		●	1x9073-2LA	0.94	2735	2.3	4.8	29						
MONED (MOPED) 95/125-7		125	7			1x7070-8AB	0.09	630	0.36	2.2	49						
MONED (MOPED) 100/210-9	63 – 95	210	9			1x7070-6AA	0.18	850	0.74	2.3	49						
MONED (MOPED) 100/185-15		185	15			1x7073-6AA	0.25	860	0.79	2.7	49						
MONED (MOPED) 100/150-25	150	150	25			1x7080-6AA	0.37	920	1.20	3.1	41						
MONED (MOPED) 100/170-40	170	170	40			1x7080-4AA	0.55	1395	1.45	3.9	41						
MONED (MOPED) 100/150-63	63 – 100	150	63		●	1x7083-4AA	0.75	1395	1.86	4.0	42						
MONED (MOPED) 100/200-80		200	80		●	1x7083-2AA	1.1	2845	2.40	6.1	43						
MONED (MOPED) 100/130-100		130	100		●	1x7090-4AA	1.1	1415	2.55	4.3	50						
MONED (MOPED) 100/150-145		150	145		●	1x7090-2AA	1.5	2860	3.25	5.5	51						
MONED (MOPED) 125/190-7	100 – 125	190	7	2 – 1400		1x7073-8AB	0.12	645	0.51	2.2	49						
MONED (MOPED) 160/210-9		210	9			1x7070-6AA	0.18	850	0.74	2.3	49						
MONED (MOPED) 160/220-16		220	16			1x7080-6AA	0.37	920	1.20	3.1	50						
MONED (MOPED) 160/250-25		250	25			1x7083-6AA	0.55	910	1.60	3.4	42						
MONED (MOPED) 160/245-40		245	40			1x7083-4AA	0.75	1395	1.86	4.0	42						
MONED (MOPED) 160/300-65	100 – 160	300	65		●	1x7096-4AA	1.5	1420	3.40	5.0	54						
MONED (MOPED) 160/250-80		250	80		●	1x7090-2AA	1.5	2860	3.25	5.5	46						
MONED (MOPED) 160/210-100		210	100		●	1x7096-4AA	1.5	1420	3.40	5.0	54						
MONED (MOPED) 160/250-145		250	145		●	1x7096-2AA	2.2	2880	4.55	6.3	54						

MONED (MOPED) 245/340-7	160 – 245	340	7			1x7083-8AB	0,25	680	1,03	2,6	52		X X 6 X XED X
MONED (MOPED) 250/350-9		350	9			1x7080-6AA	0,37	920	1,20	3,1	50		X X 0 X XED X
MONED (MOPED) 250/360-16	160 – 250	360	16			1x7083-6AA	0,55	910	1,60	3,4	52		X X 1 X XED X
MONED (MOPED) 250/360-25		360	25			1x7090-6AA	0,75	915	2,10	3,7	45		X X 2 X XED X
MONED (MOPED) 240/310-40	160 – 240	310	40			1x7090-4AA	1,1	1415	2,55	4,3	45		X X 3 X XED X
MONED (MOPED) 230/300-65	160 – 230	300	65		2 – 1400	1x7096-4AA	1,5	1420	3,40	5,0	54		X X 4 X XED X
MONED (MOPED) 250/425-80	160 – 250	425	80			1x7096-2AA	2,2	2880	4,55	6,3	49		X X 5 X XED X
MONED (MOPED) 195/250-145	160 – 195	250	145			1x7096-2AA	2,2	2880	4,55	6,3	54	5 2 0 3 2	X X 7 X XED X
MONED (MOPED) 400/640-7	230 – 400	640	7			1x7096-8AB	0,55	675	1,58	3,0	55		X X E X XED X
MONED (MOPED) 400/530-10	230 – 400	530	10			1x7083-6AA	0,55	910	1,6	3,4	53		X X F X XED X
MONED (MOPED) 400/515-16	230 – 400	515	16			1x7090-6AA	0,75	915	2,1	3,7	55		X X H X XED X
MONED (MOPED) 400/548-25	230 – 400	548	25			1x7096-6AA	1,1	915	2,9	3,8	48		X X J X XED X
MONED (MOPED) 400/580-40	230 – 400	580	40			1x9090-4LA	1,8	1480	3,9	5,1	48		X X K X XED X
MONED (MOPED) 380/490-75	230 – 380	490	75			1x9096-4LA	2,5	1490	5,9	5,1	58		X X L X XED X
MONED (MOPED) 380/490-140	230 – 380	490	140			1x9096-2LA	3,8	2810	7,9	6,5	57		X X M X XED X
MONED (MOPED) 500/720-16		720	16			1x7107-8AB	1,1	680	2,90	3,4	97		X X 0 X XED X
MONED (MOPED) 500/650-25		650	25			1x7096-6AA	1,1	915	2,90	3,8	90		X X 1 X XED X
MONED (MOPED) 500/690-40	250 – 500	690	40		2 – 1080	1x7113-6AA	2,2	940	5,20	4,6	93	5 2 0 3 3	X X 2 X XED X
MONED (MOPED) 500/765-63		765	63			1x7107-4AA	3,0	1420	6,40	6,2	90		X X 3 X XED X
MONED (MOPED) 500/650-100		650	100			1x7113-4AA	4,0	1440	8,20	6,5	97		X X 4 X XED X
MONED (MOPED) 630/900-16		900	16			1x7113-8AB	1,5	705	3,90	3,7	99		X X 0 X XED X
MONED (MOPED) 630/835-20		835	20			1x7106-6AA	1,5	925	3,90	4,2	99		X X 1 X XED X
MONED (MOPED) 630/945-35	320 – 630	945	35			1x7106-4AA	2,2	1420	4,70	5,5	97		X X 2 X XED X
MONED (MOPED) 630/1000-63		1000	63			1x7113-4AA	4,0	1440	8,20	6,5	97		X X 3 X XED X
MONED (MOPED) 1000/1530-16	500 – 1000	1530	16		2 – 1080	1x7115-8AB	2,2	700	6,20	4,2	102	5 2 0 3 4	X X 5 X XED X
MONED (MOPED) 930/1210-22	500 – 930	1210	22			1x7113-6AA	2,2	940	5,20	4,6	102		X X 6 X XED X
MONED (MOPED) 1000/1330-35	500 – 1000	1330	35			1x7107-4AA	3	1420	6,40	5,6	100		X X 7 X XED X
MONED (MOPED) 1100/1530-63	500 – 1100	1530	63			1x9113-4LA	5,5	1440	12,10	6,8	109		X X 9 X XED X
MONED (MOPED) 1250/1640-45	630 – 1250	1640	45			1x7134-6AA	5,5	950	12,80	5,0	211		X X 0 X XED X
MONED (MOPED) 1250/1720-70		1720	70			1x7133-4AA	7,5	1455	15,20	6,7	206		X X 1 X XED X
MONED (MOPED) 930/1200-100	630 – 930	1200	100		2 – 1080	1x7133-4AA	7,5	1455	15,20	6,7	206	5 2 0 3 5	X X 2 X XED X
MONED (MOPED) 2000/2600-70	1000 – 2000	2600	70			1x9133-4LA	11	1450	22,5	7,4	217		X X 3 X XED X
MONED (MOPED) 1400/1850-100	800 – 1400	1850	100			1x9133-4LA	11	1450	22,5	7,4	217		X X 4 X XED X
MONED (MOPED) 2500/3550-20	1000 – 2500	3550	20			1x7134-6AA	5,5	950	12,80	5,0	309		X X 0 X XED X
MONED (MOPED) 2500/3700-30		3700	30			1x7133-4AA	7,5	1455	15,20	6,7	304		X X 1 X XED X
MONED (MOPED) 2000/2600-40	1000 – 2000	2600	40		2 – 460	1x7133-4AA	7,5	1455	15,20	6,7	304	5 2 0 3 6	X X 2 X XED X
MONED (MOPED) 4000/5600-30	2000 – 4000	5600	30			1x9133-4LA	11	1450	22,5	7,4	315		X X 3 X XED X
MONED (MOPED) 2800/4000-40	1600 – 2800	4000	40			1x9133-4LA	11	1450	22,5	7,4	315		X X 4 X XED X

Note:

- 1) The rated torque is 60 % of the maximum tripping torque for duty S2 and 40 % of the maximum tripping torque for duty S4.
- 2) The weight data apply to the version with connecting dimensions C, D, E.
- 3) Type of electric motors: For actuators MODACT MONED and MODACT MOPED, the symbols xx are replaced with letters LA and PP, respectively.
- 4) ● – Mark of actuators filled with oil. Other actuators are filled with plastic lubricant.

Table 2 – Electric actuators MODACT MONEDJ – basic parameters
 – supply voltage 1 x 230 V, 50 Hz, protective enclosure IP 55

Type marking	Torque [Nm]		Adjusting speed [1/min]	Working stroke [revol.]	Type of lubricant	Electric motor					Weight [kg]	Type No.									
	Tripping	Starting				Type of el. motor	Power [kW]	RPM [1/min]	I _n (230 V) [A]	I _Z / I _n [-]		basic					additional				
												1	2	3	4	5	6	7	8	9	10
MONEDJ 40/75-25	20 – 40	75	25	2-1980		1LF7070-4	0,25	1400	1,86	3,4	27	5 2 0 3 0	x	x	2	x	NEDJ	x			
MONEDJ 40/50-40		50	40			1LF7070-4	0,25	1400	1,86	3,4	27		x	x	3	x	NEDJ	x			
MONEDJ 40/60-50		60	50		◆	1LF7070-2	0,37	2895	2,85	3,5	27		x	x	4	x	NEDJ	x			
MONEDJ 40/60-80		60	80		◆	1LF7073-2	0,55	2860	4,15	3,7	27		x	x	5	x	NEDJ	x			
MONEDJ 80/135-25		40 – 80	135		25		1LF7073-4	0,37	1400	2,6	3,2		27	x	x	8	x	NEDJ	x		
MONEDJ 70/90-40		40 – 70	90		40		1LF7073-4	0,37	1400	2,6	3,2		28	x	x	9	x	NEDJ	x		
MONEDJ 75/100-50		40 – 75	100		50	◆	1LF7073-2	0,55	2860	4,15	3,7		28	x	x	A	x	NEDJ	x		
MONEDJ 110/143-25		80 – 110	143		25		1LF7073-4	0,37	1400	2,6	3,2		28	x	x	E	x	NEDJ	x		
MONEDJ 100/130-40	63 – 100	130	40	2-1400		1LF7080-4	0,55	1415	3,5	3,6	41	5 2 0 3 1	x	x	3	x	NEDJ	x			
MONEDJ 95/124-63	63 – 95	124	63		◆	1LF7083-4	0,75	1405	4,8	3,9	42		x	x	4	x	NEDJ	x			
MONEDJ 100/230-80	63 – 100	130	80		◆	1LF7083-2	1,1	2860	6,7	4,4	43		x	x	E	x	NEDJ	x			
MONEDJ 100/130-100		130	100		◆	1LF7096-4	1,5	1430	8,7	4,3	50		x	x	5	x	NEDJ	x			
MONEDJ 95/124-145	63 – 95	124	145		◆	1LF7090-2	1,5	2845	9,25	4,5	51		x	x	F	x	NEDJ	x			
MONEDJ 150/195-40	100 – 150	195	40			1LF7083-4	0,75	1405	4,8	3,9	41		x	x	9	x	NEDJ	x			
MONEDJ 160/208-65	100 – 160	208	65		◆	1LF7096-4	1,5	1430	8,7	4,3	42		x	x	A	x	NEDJ	x			
MONEDJ 160/208-80		80	◆		1LF7090-2	1,5	2845	9,25	4,5	43	x		x	H	x	NEDJ	x				
MONEDJ 130/170-145		100 – 130	170		145	◆	1LF7096-2	2,2	2830	13,3	4,8		51	x	x	J	x	NEDJ	x		
MONEDJ 250/325-40	160 – 250	325	40		2-1400		1LF7096-4	1,5	1430	8,7	4,3		45	5 2 0 3 2	x	x	3	x	NEDJ	x	
MONEDJ 220/286-80	160 – 220	286	80	◆		1LF7096-2	2,2	2830	13,3	4,8	49	x	x		5	x	NEDJ	x			

The actuators MODACT MONEDJ are fitted with single-phase electric motors Siemens series 1LF7... with running and starting-up capacitors. The manufacturer guarantees 60,000 and 100,000 start-ups for two-pole electric motors (ca 2800 r.p.m.) and four-pole electric motors (ca 1400 r.p.m.), respectively. Then, it is necessary to replace the centrifugal disconnecter of the starting-up capacitor – it is available at ZPA Pečky a.s.

In ZPA Pečky a.s., electric motors of power up to 0.37 kW are fitted with a triac disconnecter that extends the service life to 350,000 start-ups.

If the actuator with a single-phase electric motor is to be used for regulating purposes, it is necessary to take this fact into consideration in setting-up the regulation process (frequency of regulating interventions).

The expected working regime of the actuators MONEDJ should be discussed with the marketing department of ZPA Pečky, a.s.

◆ – Mark of actuators filled with oil. Other actuators are filled with plastic lubricant.

Electric actuators MODACT MONED, MOPED, MONEDJ

– Specification of meaning of the 6th to 10th place of the type number

Place in the type number... 1st 2nd 3rd 4th 5th 6th 7th 8th 9th 10th 11th
Type number5 2 0 3 x . x x x x ED (J) x

6th place of type number

Table 3

Connecting dimensions	Version	
	Bushings	Connector
Shape A	5	F
Shape B1	6	G
Shape C	7	H
Shape D	8	J
Shape E	9	K

7th place of type number

If one of numerals 1, 3, 5, 7 or 9 is on the 9th place of the type number the character from Table 4 is on the 7th place.
 If one of numerals 2, 4, 6 or 8 is on the 9th place of the type number the character from Table 5 is on the 7th place.

Table 4 – actuator fitted with electronics DMS2 ED

Outfit	0	1	2	3	4	5	6	7	8	9	A	B	C	D	E	F	H	J	K	L	M	N	V	W
Local control		x		x		x		x		x		x		x		x		x		x		x		x
Display			x	x			x	x			x	x			x	x			x	x			x	x
Contactors or contact-less switching					x	x	x	x					x	x	x	x					x	x	x	x
Analog module	transmitter								x	x	x	x	x	x	x	x	x	x	x	x	x	x	x	x
	regulator																	x	x	x	x	x	x	x

Place in the type number...1st 2nd 3rd 4th 5th 6th 7th 8th 9th 10th 11th
Type number5 2 0 3 x . x x x x ED (J) x

7th place of type number

Table 5 – actuator fitted with electronics DMS2

Two-position or three-position control *)	R
Profibus	P
Two- or three-position control, without display and local control *)	T

*) Two- or three-position regulation of the actuator is set at the manufacturer. Unless otherwise specified in the order, the actuator will be set for three-position regulation (control by signal 4 – 20 mA).

8th place of type number

Tripping torque, Adjusting speed	MODACT MONED, MOPED – Table 1
	MODACT MONEDJ – Table 2

9th place of type number

Table 6 – type of electronics, power switches, brake

Electronics DMS2 ED – without power switches	1
Electronics DMS2 – with contactors	2
Electronics DMS2 ED – with contact-less switches	3
Electronics DMS2 – with contact-less switches	4
Electronics DMS2 ED – with contactors and brake *)	5
Electronics DMS2 – with contactors and brake	6
Electronics DMS2 ED – with contact-less switches and brake *)	7
Electronics DMS2 – with contact-less switches and brake	8
Electronics DMS2 ED – with contactors	9

Note: Version 52 03x.xxxxNEDJ is delivered in version 52 03x.xxx1NEDJ, 52 03x.xxx2NEDJ or 52 03x.xxx9NEDJ.

*) If the actuator has DMS2 ED electronic system in configuration Electromechanics board replacement, the electronic brake will not be delivered.

10th place of type number

Protective enclosure: MONED, MONEDJ – IP 55; MOPED – IP 67

11th place of type number

Table 7 – Surrounding temperatures

Type of actuator						Temperature [°C]	Code
MONED		MOPED		MONEDJ			
DMS2 ED	DMS2	DMS2 ED	DMS2	DMS2 ED	DMS2		
✓	✓	✓	✓	✓	✓	-25 +60	–
✓	✓	✓	✓	✓	✓	-40 +60	F1
✓	✓	✓	✓	✓	✓	-50 +60	F
✓	x	x	x	x	x	-60 +60	FF
✓*	x	✓*	x	x	x	-25 +80	T
✓*	x	✓*	x	x	x	-40 +80	F1T
✓*	x	✓*	x	x	x	-50 +80	FT

Note: ✓ – available version
 x – not available
 ✓* – except for the version with current transducer of position, with analog control module, and/or with built-in display

Dimensional sketch of electric actuators MODACT MONED, MOPED

Type No. 52 030 – 52 035 (version with terminal board)

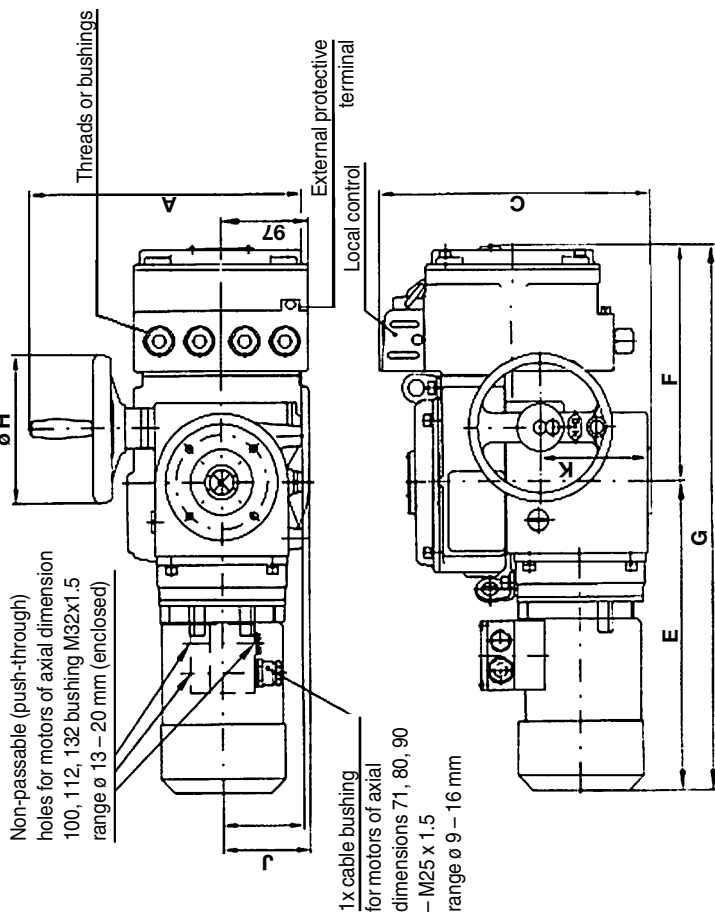

Type designation	A	B	C	D	E	F	G	ø H	J	K
52 030.xxxxNED	305	90	300	76	334	258	592	160	99	120
52 031.xxxxNED 52 032.xxxxNED	376	120	328	92	436	258	694	200	-	144
52 033.xxxxNED 52 034.xxxxNED	455	145	387	123	519	288	807	250	-	190
52 035.xxxxNED	540	178	445	153	598	298	328	926	-	234

Note: For actuators MODACT MONED, MOPED, the switchboard box has threads for bushings: 3 x thread M20 x 1.5; 1 x thread M25 x 1.5 (the bushings are included in the delivery - wrapped-together part). For actuators MODACT MOPED, the switchboard box has bushings: 1 x M25 x 1.5, range of Ø 13 – 18 mm; 2 x M20 x 1.5, range of Ø 10 – 14 mm; 1 x M20 x 1.5, range of Ø 6 – 12 mm. The electric motor (except for the actuator version with the switchboard box) is always delivered with cable bushing. Connector Harting is always fitted with cable bushings.

Dimensional sketch of electric actuators MODACT MONED, MOPED

Type No. 52 036 (version with terminal board)

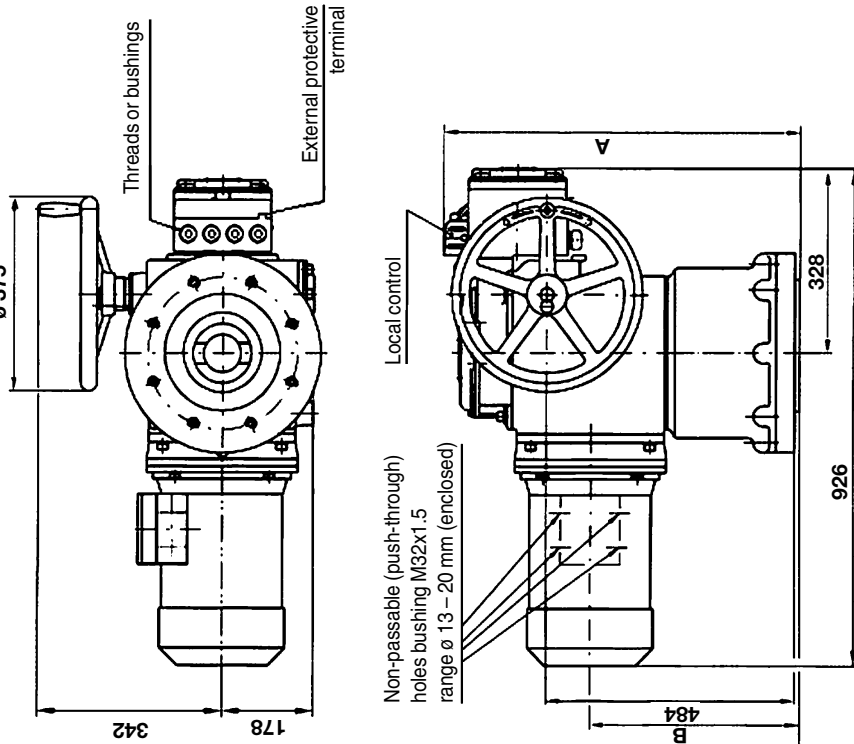

Type designation	A	B
52 036.xxxxNED shape A	785	463
52 036.xxxxNED shape B ₁ , C, D, E	740	418

Dimensional sketch of electric actuators MODACT MONED, MOPED

Type No. 52 030.xxxxNED – 52 035 (version with connector)

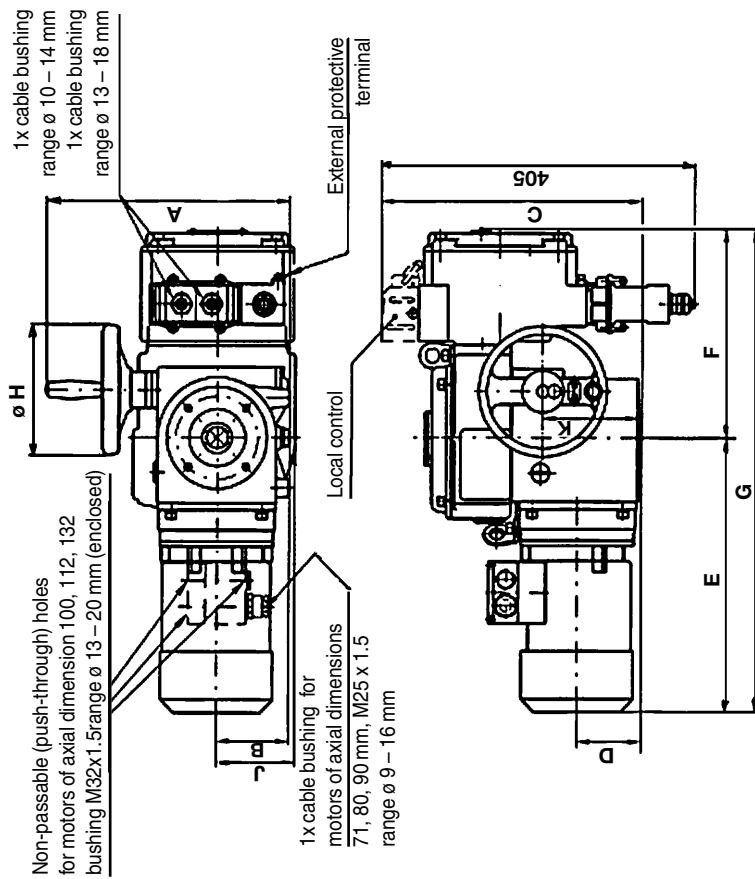

Type designation	A	B	C	D	E	F	G	H	J	K
52 030.xxxxNED	305	90	325	78	334	258	592	160	99	120
52 031.xxxxNED 52 032.xxxxNED	376	120	350	92	436	258	694	200	-	144
52 033.xxxxNED 52 034.xxxxNED	455	145	410	123	519	288	807	250	-	190
52 035.xxxxNED	540	178	470	153	598	328	926	375	-	234

Dimensional sketch of electric actuators MODACT MONED, MOPED

Type No. 52 036 (version with connector)

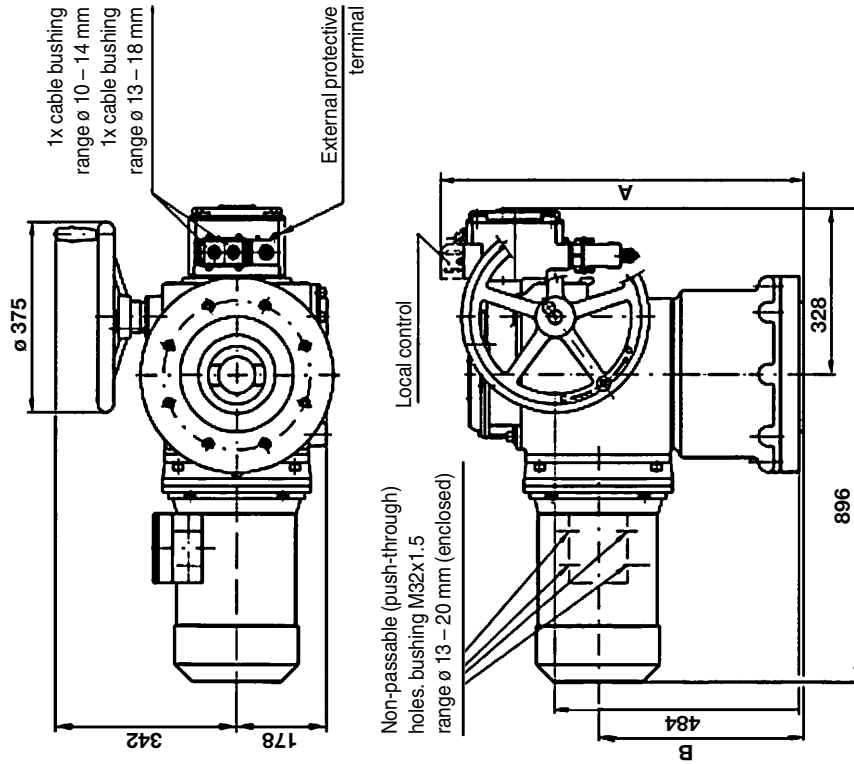

Type designation	A	B
52 036.xxxxNED shape A	785	463
52 036.xxxxNED shape B ₁ , C, D, E	740	418

Holes for additional fastening of actuators **MODACT MONED, MOPED,**
Type No. 52 030 – 52 035

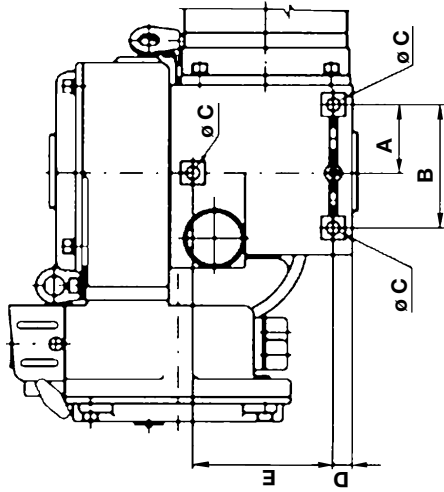

Type designation	Dimension (mm)				
	A	B	ø C	D	E
52.030.xxxxN	61	110	M10	16	120
52.031.xxxxN 52.032.xxxxN	90	160	M12	21	140
52.033.xxxxN 52.034.xxxxN	110	210	M16	23	200
52.035.xxxxN	120	240	M20	47	220

Note:
The holes for additional fastening of actuators MODACT serve only for catching the weight of the actuators and should not be exposed to any other additional force.

Modification for rising spindle

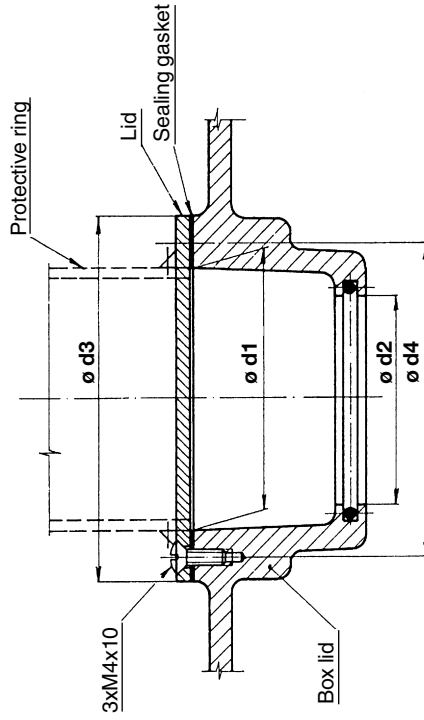

Dimensions (mm)	Type number				
	52 030	52 031 52 032	52 033 52 034	52 035	52 036
ø d ₁	45	60	80	90	90
ø d ₂	35,5	50,5	75	80,5	80,5
ø d ₃	65	80	110	110	110
ø d ₄	55	70	100	100	100

Protective adapter (including lid hole) – to be made by the customer.

Connecting dimensions of actuators
MODACT MONED, MOPED, MOPED, Type No. 52 030 – 52 036
 – basic version (*without adapter*)

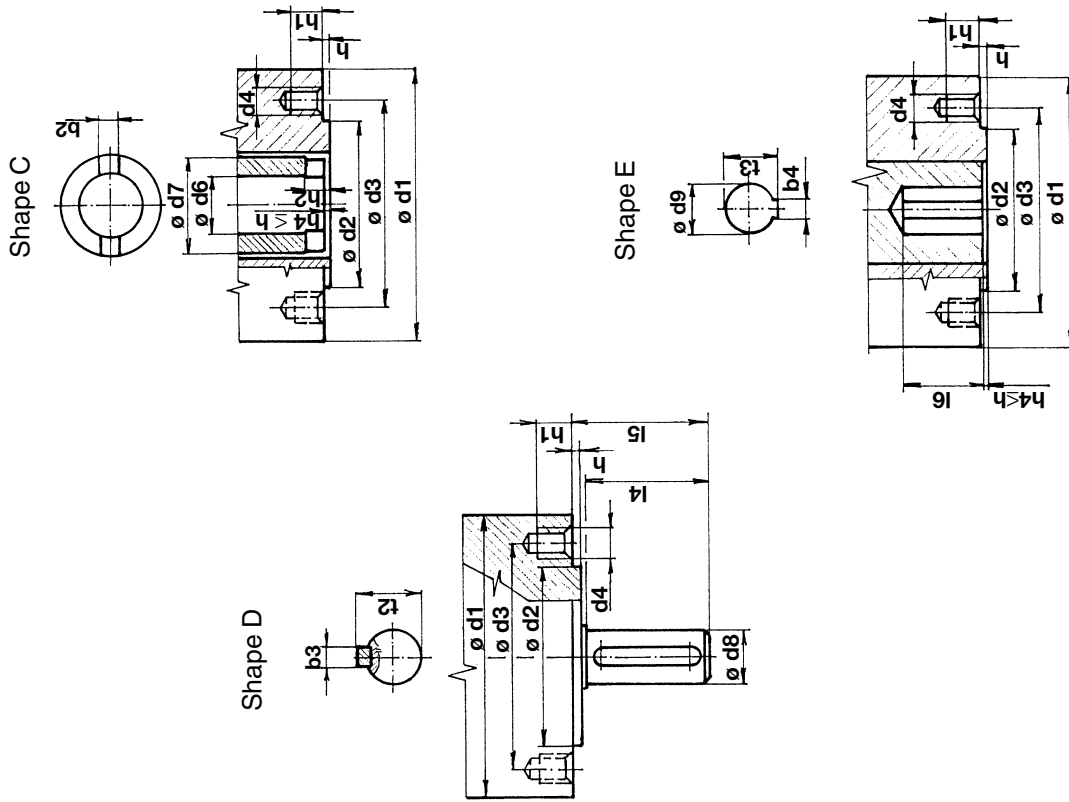

Table of basic connecting dimensions of actuators
MODACT MONED, MOPED (*without adapter*)

Shape	Dimension (mm)	Type number			
		52 030	52 031 52 032	52 033 52 034	52 035 52 036
C, D, E (<i>identical dimensions</i>)	$\varnothing d1$ orientational value	125	175	210	300
	$\varnothing d2$ f8	70	100	130	200
	$\varnothing d3$	102	140	165	254
	d4	M 10	M 16	M 20	M 16
	number of threaded holes	4	4	4	8
	hmax	3	4	5	5
C	h1 min. 1,25d4	12,5	20	25	20
	$\varnothing d7$	40	60	80	100
	h2	10	12	15	16
	b2 H11	14	20	24	30
	$\varnothing d6$	28	41,5	53	72
	$\varnothing d8$ g6	20	30	40	50
D	l4	50	70	90	110
	l2max	22,5	33	43	53,5
	b3 h9	6	8	12	14
	l5	55	76	97	117
	$\varnothing d9$ H8	20	30	40	50
	l6 min.	55	76	97	117
E	t3	22,8	33,3	43,3	53,8
	b4 Js9	6	8	12	14

The dimensions $\varnothing d6$ and $l6$ must not be lower than values in the table.
 The dimensions are given in mm.

Adapters to actuators **MODACT MONED, MOPED,**

Type No. 52 030 – 52 035

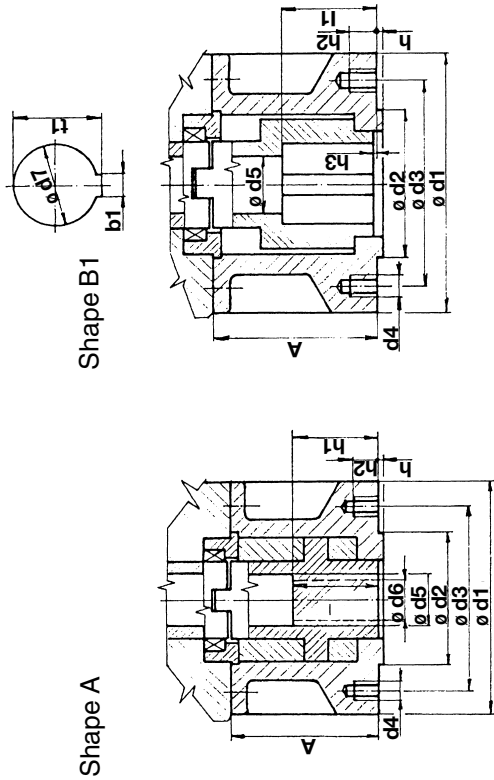

Assignment of adapters to actuators

Shape	Dimensions (mm)	Type number			
		52 030	52 031 52 032	52 033 52 034	52 035
A, B1 (identical dimensions)	ø d1	125	175	210	300
	ø d2 f8	70	100	130	200
	ø d3	102	140	165	254
	d4	M 10	M 16	M 20	M 16
	number of holes d4	4	4	4	8
	h	3	4	5	5
	h2 min.	12,5	20	25	20
	A	63,5	110	179	155
	ø d5	30	38	53	63
	ø d6 max	26	36	44	60
A	h1 max	43,5	65	92	110
	l min	45	55	70	90
	A	63,5	110	122	155
	ø d5	30	40	50	65
B1	l1 min	45	65	80	110
	h3 max	3	4	5	5
	b1	12	18	22	28
	ø d7 H9	42	60	80	100
	t1	45,3	64,4	85,4	106,4

Adapters to actuators **MODACT MONED, MOPED,**

Type No. 52 036

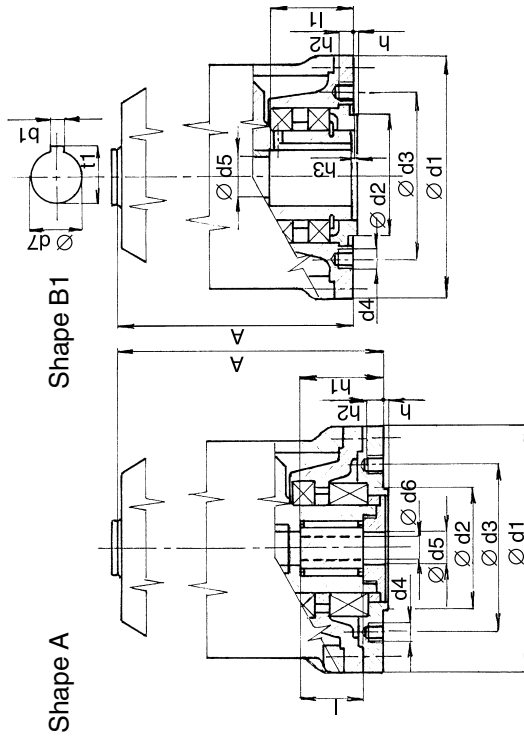

Shape	Dimensions [mm]	52 036
A, B1 (identical dimensions)	ø d1	390
	ø d2 f8	230
	ø d3	298
	d4	M 20
	number of holes d4	8
	h	5
	h2 min.	25
	A	740 1+)
	ø d5	72
	ø d6 max	70
A	h1 max	165
	l min	110
	A	695 2+)
	ø d5	72
B1	l1 min	130
	h3 max	5
	b1	32
	ø d7 H9	120
	t1	127,4

Notes:

1+) – The nut is built-in into the actuator

2+) – The case is built-in into the actuator



Development, production and services of electric actuators and switchboards.
Top-quality sheet-metal processing (TRUMPF equipment), powder paint shop.

SURVEY OF PRODUCED ACTUATORS

KP MINI, KP MIDI

Electric rotary (90°) actuators (up to 30 Nm)

MODACT MOK, MOKED, MOKP Ex

Electric rotary (90°) actuators for ball valves and flaps

MODACT MOKA

Electric rotary (90°) actuators for nuclear power stations application outside containment

MODACT MON, MOP, MONJ, MONED, MOPED, MONEDJ

Electric rotary multi-turn actuators

MODACT MO EEX, MOED EEX

Explosion proof electric multi-turn actuators

MODACT MOA

Electric multi-turn actuators for nuclear power stations application outside containment

MODACT MOA OC

Electric multi-turn actuators for nuclear power stations application inside containment

MODACT MPR VARIANT

Electric rotary (160°) lever actuators with a variable output speed

MODACT MPS KONSTANT, MPSED

Electric rotary (160°) lever actuators with a constant output speed

MODACT MTN, MTP, MTNED, MTPED

Electric linear thrust actuators with a constant output speed

Deliveries of assembled actuator + valve (or MASTERGEAR gearbox) combinations

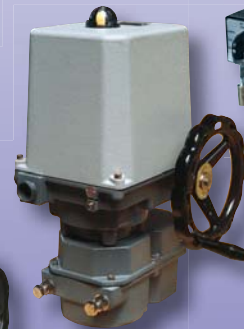
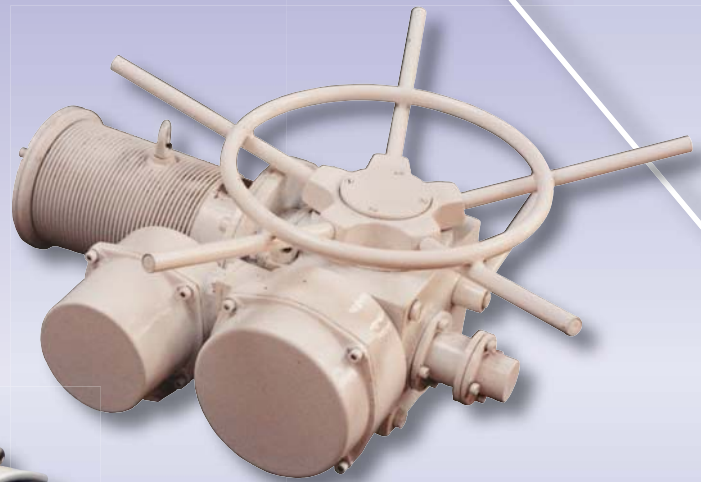
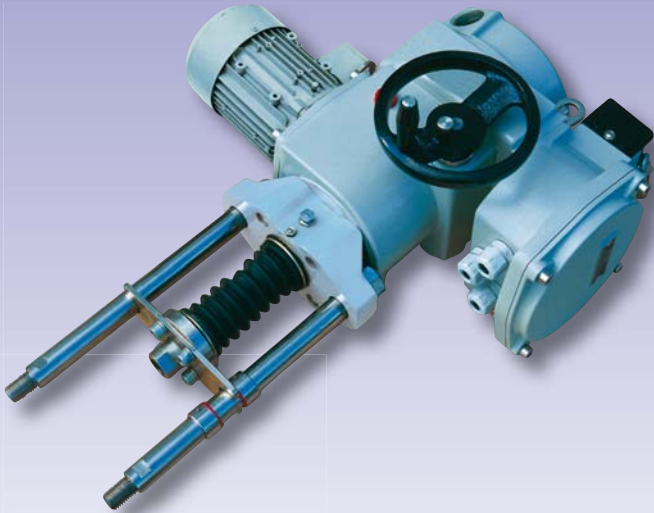

ZPA Pečky, a.s.
tř. 5. května 166
289 11 PEČKY, Czech Republic
www.zpa-pecky.cz

tel.: +420 321 785 141-9
fax: +420 321 785 165
+420 321 785 167
e-mail: zpa@zpa-pecky.cz